

**READ THIS BEFORE
INSTALLING
SWITCHGEAR**

SYSTEM 2000

SWITCHGEAR

INSTALLATION GUIDE

PM073 Rev 1 14/02/17

TABLE OF CONTENTS

1. EQUIPMENT STORAGE	1
2. EQUIPMENT OPERATING	1
3. ELECTRICAL RATINGS	2
4. ENCLOSURE TYPE	2
5. SWITCHGEAR ACCESS	2
6. VENTILATION	2
7. FLOOR MOUNTING	2
8. BOLT DOWN PROVISIONS	3
9. SHIPPING SPLITS	3
10. CABLE CONNECTIONS	4
11. CABLE TORQUE REQUIREMENTS	4
11.1. Blackburn - Thomas & Betts Tightening Torque Values	4
11.2. IlSCO Tightening Torque Values	5
11.3. ABB Tightening Torque Values	5
12. EXTERNAL WIRING	7
13. CLEANING	8
14. INSULATION RESISTANCE TESTING/ DIELECTRIC TESTING	8
15. BATTERY CHARGER	8
16. INSTALLATION MOUNTING DRAWINGS	9

NOTE:

The following information is provided as a general guide for installing Thomson Power Systems System 2000 Switchgear in typical applications. System installations must be done in accordance with all applicable local and national electrical regulation codes and practices as required. If you have any concerns or require detailed information to aid in installation, contact the Thomson Power Systems Service Group.

1. EQUIPMENT STORAGE

CAUTION!!!

Failure to store and operate equipment under the specified environmental conditions may cause equipment damage and void warranty.

The switchgear shall be stored in an environment with a temperature range not exceeding -4° to +158° Fahrenheit (-20° to +70° Celsius) and a humidity range not exceeding 5%-95% non-condensing. Before storing, unpack sufficiently to check for concealed damage. If concealed damage is found, notify the switchgear supplier and the carrier immediately. Repack with the original, or equivalent packing materials. Protect from physical damage. Store indoor in a clean, dry, well-ventilated area free of corrosive agents including fumes, salt and concrete/cement dust. Apply heat as necessary to prevent condensation.

NOTE:

If the switchboard is unpacked and positioned prior to completion of room/building construction, heavy cardboard should be used to protect the equipment and wiring from damage, dirt, and defacing during building construction.

2. EQUIPMENT OPERATING

The switchgear shall be operated in an environment with a temperature range not exceeding +5° to +122° Fahrenheit (-15° to +50° Celsius) and a humidity range not exceeding 5%-95% non-condensing.

3. ELECTRICAL RATINGS

Before installing the switchgear ensure all electrical ratings of the equipment (i.e. voltage (AC and DC), current and interrupting ratings etc.) are suitable for the system it is being connected to. All equipment ratings are shown on an Equipment Identification nameplate on the front door(s) of the switchgear.

Also verify cable entries are in the correct location and power connection (lugs) are suitable. Check that the appropriate system configuration is supplied 1-Phase, 2-Wire / 1-Phase, 3-Wire / 3-Phase, 3-Wire / 3-Phase, 4-Wire.

4. ENCLOSURE TYPE

Ensure the enclosure type is correct for the environment the switchgear is being installed.

- NEMA1 Indoor (ventilated - no protection)
- NEMA2 Indoor (some protection against vertical drops of water i.e. condensation)
- NEMA12 Indoor (oil and dust tight - gaskets and filter media)
- NEMA3R Outdoor (weather proof)
- Other

5. SWITCHGEAR ACCESS

Standard switchgear designs require front and rear access. Sufficient access and working space shall be provided to permit safe operation and maintenance of the switchgear. Minimum clear distances for all workspace around the switchgear shall be provided as defined in the National Electrical code (NEC) or Canadian Electrical code (CEC).

6. VENTILATION

Unless there is specific requirement, switchgear is provided with ventilation (front and back). The ventilation must not be blocked or reduced in anyway.

7. FLOOR MOUNTING

The switchgear is suitable only for installation on a non-combustible floor.

It is critical that a flat, even and level finished floor is provided. If the floor is not level it will cause distortion of the switchgear; most noticeably:

- ❑ Hinged doors will not line up and may not swing freely.
- ❑ Removable covers may not line up.
- ❑ Bus splice plates may be difficult to install.
- ❑ General stress on the enclosure, bus and bus supports.

8. BOLT DOWN PROVISIONS

Standard Thomson Power Systems System 2000 switchgear enclosures include provisions for fastening the enclosure to the floor; refer to drawing 099C005.

9. SHIPPING SPLITS

Large switchgear lineups are provided with shipping splits. When placing the switchgear ensure the sections are lined up and placed tightly together without a gap. Do not use the hardware supplied to pull the sections together. This will deform the structure.

Nuts and bolts will be supplied to join the perforated rails every 18 - 24". Insert the bolts per drawing 099C004, spaced every 18 - 24". Just hand tighten until all sections have been joined. Once all bolts have been placed in a satisfactory pattern, tighten the bolts using a wrench.

Where load bus bars cross a shipping split, the load bus will be drilled and bus splice plates provided. The necessary hardware will be provided to connect the bus across the shipping split on site, refer to drawing 099C002, 099C003 and CDB1242 as applicable.

CAUTION!!!

Before placing the switchgear into service, it is imperative to check all electrical connections and mechanical fasteners for correct tightness. Failure to do so may cause severe equipment damage or failure.

Control wiring that spans the shipping split will be fitted across the shipping split at the factory. The wiring will terminate at a terminal strip. Prior to shipping, the wiring will be disconnected at the terminal strip, pulled back and bundled within the control compartment. Once the switchgear has been placed and joined, the wiring can be drawn back across the shipping split and reconnected at the terminal strip. The wire numbers match the terminal numbers; any

variation will be shown on the "As Built" schematics shipped with the switchgear; reference these schematics when reconnecting the wiring.

10. CABLE CONNECTIONS

During power cable installation, ensure the phasing of all line/load conductors are correctly matched between the connected sources and the switchgear bus bar.

NOTE:

Unless otherwise stated in the switchgear drawings, the switchgear is designed as standard to accept sources with a positive (i.e. A-B-C) phase rotation. It is recommended the phase rotation of the system sources be confirmed prior to installation of the power caballing.

All cable lugs shall be adequately torqued as per the following manufacturer's instructions.

CAUTION!!!

Before placing the switchgear into service, it is imperative to check all electrical connections and mechanical fasteners for correct tightness. Failure to do so may cause severe equipment damage or failure.

11. CABLE TORQUE REQUIREMENTS

11.1. Blackburn - Thomas & Betts Tightening Torque Values

ADR21, T&B, LUG, SCREW TYPE, (1)#14-2/0 CU/AL

ADR25, T&B, LUG, SCREW TYPE, (1)#6-250MCM

ADR35, T&B, LUG, SCREW TYPE, (1) #6-350MCM

ADR60, T&B, LUG, SCREW TYPE, (1)#2-600MCM

Tightening Torque Values for Aluminum Dual Rated Socket Screw Connectors					
AWG or Circular Mill size	Tightening Torque is in lb. Screw Driver Wrench		AWG or Circular Mill size	Tightening Torque is in lb. Screw Driver Wrench	
	12	20		75	400
10	20	75	250	-	250
9	20	75	350	-	250
6	35	100	500	-	300

Tightening Torque Values for Aluminum Dual Rated Socket Screw Connectors					
AWG or Circular MII size	Tightening Torque is in lb. Screw Driver Wrench		AWG or Circular MII size	Tightening Torque is in lb. Screw Driver Wrench	
	4	35		100	600
2	50	125	700	-	300
1	50	125	750	-	300
1/0	50	150	900	-	400
2/0	50	150	1000	-	400
3/0	-	200			

11.2. IlSCO Tightening Torque Values

TA800I, ILSCO, LUG, SCREW TYPE, (1) 300-800MCM CU/AL

Tightening Torque Values for ILSCO Socket head Screw Connectors	
Internal Socket Size Across Flats Inches	Tightening Torque in Inch Pounds
1/8	45
5/32	100
3/16	120
7/32	150
1/4	200
5/16	275
3/8	375
1/2	500
9/16	600

11.3. ABB Tightening Torque Values

K6TP, ABB, BREAKER LUG KIT, 800A, S6 3 LUGS/KIT, (3) 2/0-500MCM CU/AL

K4TB, ABB, BREAKER LUG KIT, 100A, S3-4 3 LUGS/KIT, (1)#14-1/0 CU/AL

K7TK, ABB, BREAKER LUG KIT, 1200A, S7 CSA/UL, SINGLE UNIT

K4TC, ABB, BREAKER LUG KIT, 150A, S3-4 3 LUGS/KIT, (1)#2-4/0 CU/AL

K4TE, ABB, BREAKER LUG KIT, 250A, S4 3 LUGS/KIT, (1)#6-350MCM CU/AL

K5TG, ABB, BREAKER LUG KIT, 400A, S5 3 LUGS/KIT, (2) 3/0-250MCM CU/AL

K5TF, ABB, BREAKER, LUG KIT, 300A, S5 (1) 250-500MCM CU/AL, 3 LUGS/KIT

K5TGS, ABB, BREAKER, LUG KIT, SADDLE, S5 (1) 250-500MCM CU, 6 LUGS/KIT

K7TK-1, ABB, BREAKER, LUG, 1000 - 1200A, 4/0-500 MCM, CSA/UL, SINGLE UNIT

K6THW, ABB, BREAKER, LUG, 400/600A, S6 ALT# K6THW-B100 (2) 2/0-500MCM
CU/AL, CSA/UL

WIRE RANGE	WIRE TORQUE
14 AWG – 8 AWG	22 lb-in
6 AWG – 3 AWG	44 lb-in
COPPER WIRE ONLY	

FIGURE	LUG KIT CAT. NO.	LUG NO.	TEMP.	WIRE RANGE	WIRE TORQUE	MOUNTING TORQUE	WIRE SCREW SIZE
A	K3TA, K3TA-2	D3477	75°C	14 AWG – 2 AWG	50 lb-in	120 lb-in	SLOT
B	K4TB, K4TB-2	D3447	75°C	14 AWG – 1.0	50 lb-in	120 lb-in	SLOT
C	K4TC, K4TC-2	D3449	75°C	2 AWG – 4.0	120 lb-in	150 lb-in	3/16
D	K4TD, K4TD-2	D3448	75°C	4 AWG – 300kcmll	275 lb-in	150 lb-in	1/4

FIGURE	LUG KIT CAT. NO.	LUG NO.	TEMP.	WIRE RANGE	WIRE TORQUE	MOUNTING TORQUE	WIRE SCREW SIZE
A	K4TB, K4TB-2	D3447	75°C	14 AWG – 1.0	50 lb-in	120 lb-in	SLOT
B	K4TC, K4TC-2	D3449	75°C	2 AWG – 4.0	120 lb-in	150 lb-in	3/16
C	K4TD, K4TD-2	D3448	75°C	4AWG – 300 kcmll	275 lb-in	150 lb-in	1/4
D	K4TE, K4TE-2	D3472	75°C	6 AWG – 350kcmll	275 lb-in	150 lb-in	5/16

FIGURE	LUG KIT CAT. NO.	LUG NO.	TEMP.	WIRE RANGE	WIRE TORQUE	MOUNTING TORQUE	WIRE SCREW SIZE
F	K5TF, K5TF-2	D3450	75°C	250 – 500kcmll	375 lb-in	175 lb-in	3/8
G	K4TC, K4TC-2	D3484	75°C	3.0 – 250kcmll (2)	275 lb-in	175 lb-in	5/18

FIGURE	LUG KIT CAT. NO.	LUG NO.	TEMP.	WIRE RANGE	WIRE TORQUE	MOUNTING TORQUE	WIRE SCREW SIZE
H	K6TH, K6TH-2	D2967	90°C	250 – 500kcmll	275 lb-in	85 lb-in	5/16
J	K6TJ, K6TJ-2	D2968	90°C	2.0 – 400kcmll (2)	375 lb-in	110 lb-in	3/8

FIGURE	LUG KIT CAT. NO.	LUG NO.	TEMP.	WIRE RANGE	WIRE TORQUE	MOUNTING TORQUE	WIRE SCREW SIZE
K	K7TK, K7TK-2	D2959	90°C	4.0 – 500kcmll (4)	375 lb-in	375 lb-in	2/8

FIGURE	LUG KIT CAT. NO.	LUG NO.	TEMP.	WIRE RANGE	WIRE TORQUE	MOUNTING TORQUE	WIRE SCREW SIZE
L	K8TL	D1922	90°C	1.0 – 750kcmll (4)	500 lb-in	500 lb-in	1/2
M	K8TM	D3185, D3188, D3187	90°C	1.0 – 750kcmll (6)	500 lb-in	500 lb-in	1/2

12. EXTERNAL WIRING

The "As Built" switchgear schematics are shipped with the switchgear.

The following general guidelines apply to external wiring connections between auxiliary systems and the switchgear. Specific customer requirements, the National and/or local electrical code requirements shall take precedence over these guidelines.

- ❑ Control wiring must not be run unshielded, in parallel, and in close proximity to power cables.
- ❑ AC and DC wiring shall be run separately.
- ❑ In general, control wiring is #14AWG (2.5mmSQ) minimum unless it is determined a smaller gauge conductor is suitable.
- ❑ Recommend #10AWG (6mmSQ) for current transformer (CT) connections.
- ❑ Shielded cable #18AWG (0.75mmSQ) minimum Belden 8760 or equal. Larger if required due to distance.
- ❑ Communication cable wiring from the switchgear to remote devices must be suitably routed to protect it from sources of electrical interference. Guidelines for protection against possible electrical interference are as follows:
 - Use high quality, shielded communication cable as specified on switchgear drawings.
 - Route the communication cable at least 3 M (10') away from sources of electrical noise such as variable speed motor drives, high voltage power conductors, UPS systems, transformers, rectifiers etc.
 - Use separate, dedicated conduit runs for all communication cables. Do not tightly bundle communication cables together in the conduit. Conduit should be ferromagnetic type near sources of possible electrical interference. The entire length of conduit should be grounded to building earth ground.
 - When communication cables must cross over low or high voltage AC power conductors, the communication cables must cross at right angles and not in parallel with the conductors.

- For additional information on protection against electrical interference, contact THOMSON POWER SYSTEMS factory.
- Special consideration should be given to the control power connection. Diesel and gas generator control systems are usually powered from the 12/24Vdc engine cranking batteries. The controls are designed to withstand a short duration voltage drop in DC voltage during cranking. With voltage levels starting as low as 12 and 24Vdc it is best to minimize the amount of voltage drop across the power supply interconnect wiring. Recommend #10AWG (6mmSQ) for control power supply connections.

13. CLEANING

Switchgear should be cleaned, wiped with a dry cloth or approved electrical equipment cleaner. Care must be taken not to drop any debris into breaker arc shoots or inside component covers. Vacuum as necessary.

14. INSULATION RESISTANCE TESTING/ DIELECTRIC TESTING

Before the power cabling is terminated, all cables should have their insulation resistance tested with suitable equipment and should be checked for any potential grounds or short circuits.

The switchgear has undergone dielectric (i.e. high potential) testing at the factory prior to shipment however may be re-tested once positioned on site at the customers' discretion. All fuses should be removed and drawings reviewed to ensure no electronic components will be subjected to hi-pot testing.

15. BATTERY CHARGER

Before installing the battery charger, confirm that the electrical ratings are suitable for the power supply voltage and DC voltage for the batteries supplied.

In general, battery chargers should be located near the batteries they are charging and heavier gauge wire may be required. Refer to the manufacturer's literature for specific guidance on installation. Before energization, ensure the battery charger output is calibrated for the specific type of battery used and takes into account the voltage loss over the charging leads.

16. INSTALLATION MOUNTING DRAWINGS

Drawing No. CDB1242

FIG. 1) 3/8" FASTENERS (PREFERRED)

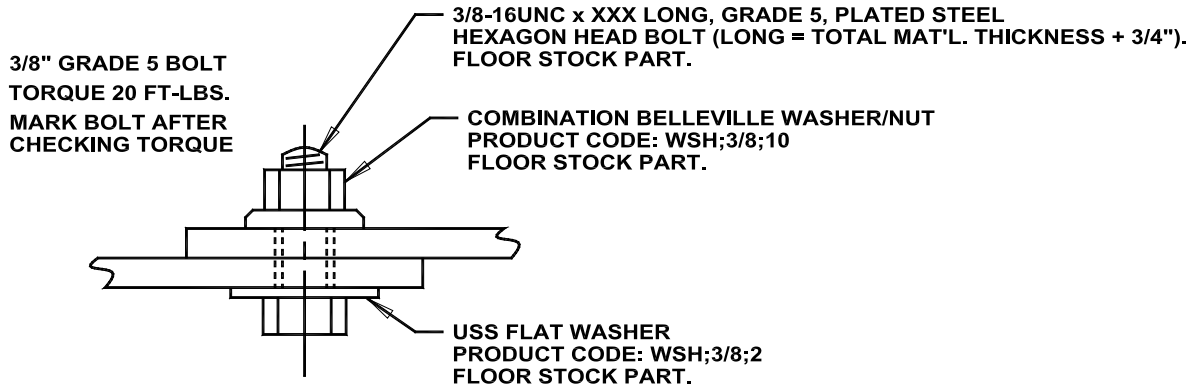
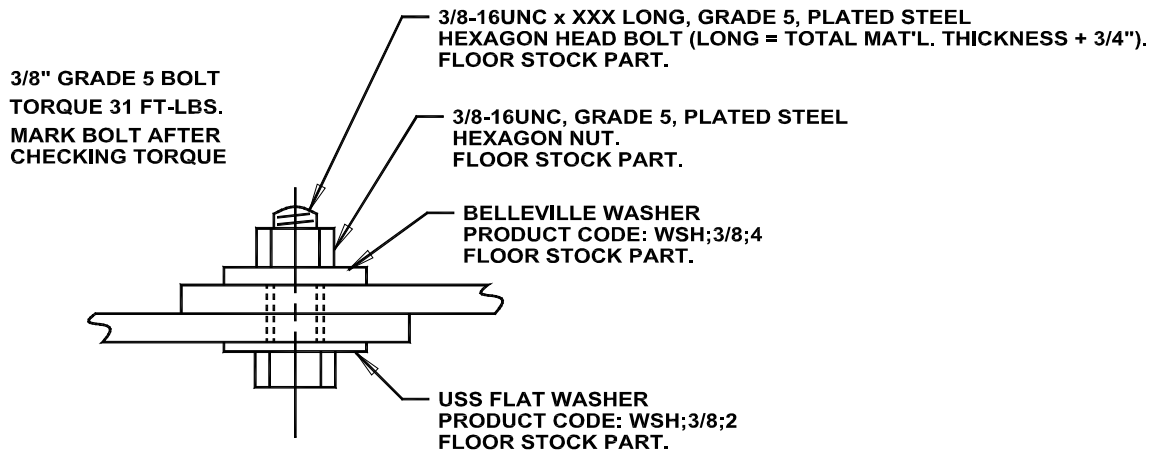

FIG. 2) 3/8" FASTENERS (ALTERNATE 1)



Drawing No. CDB1242 continued...

FIG. 3) 3/8" FASTENERS (ALTERNATE2)

COPPER ONLY

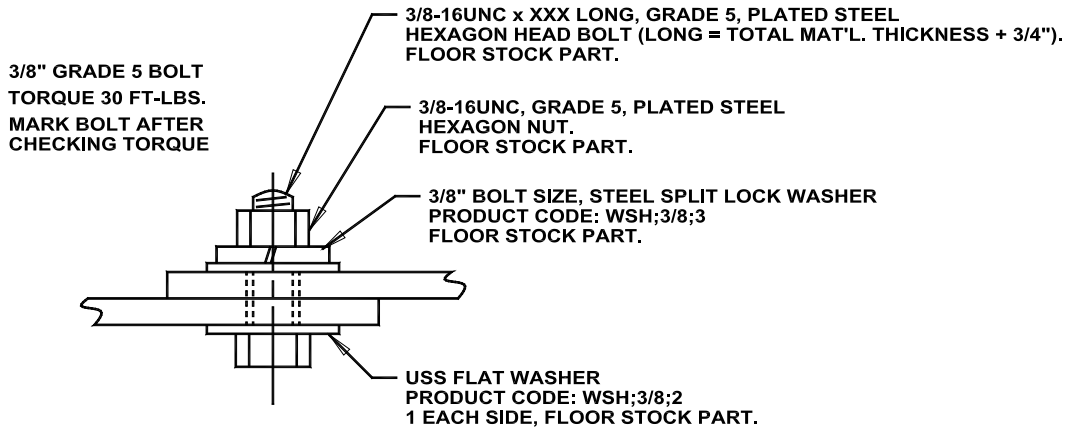
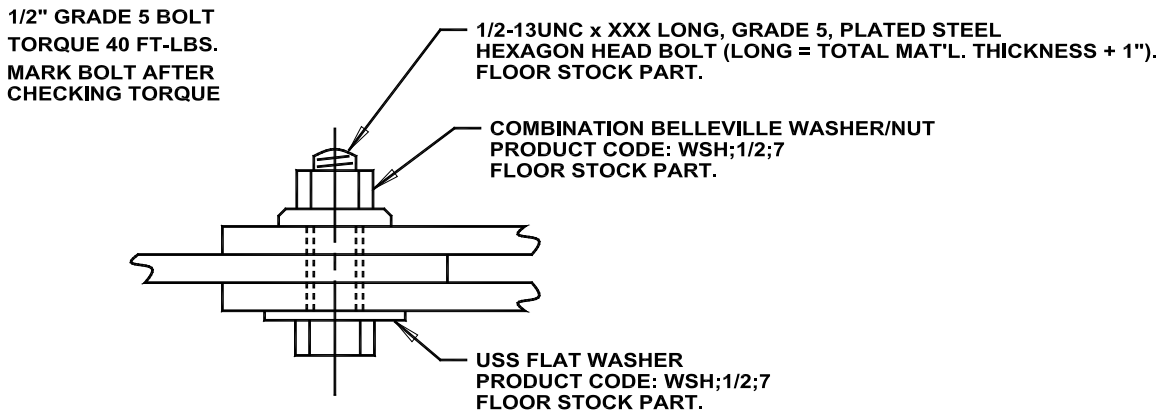

FIG. 4) 1/2" FASTENERS (PREFERRED)



Drawing Do. CDB1242 continued...

FIG. 5) 1/2" FASTENERS (ALTERNATE)

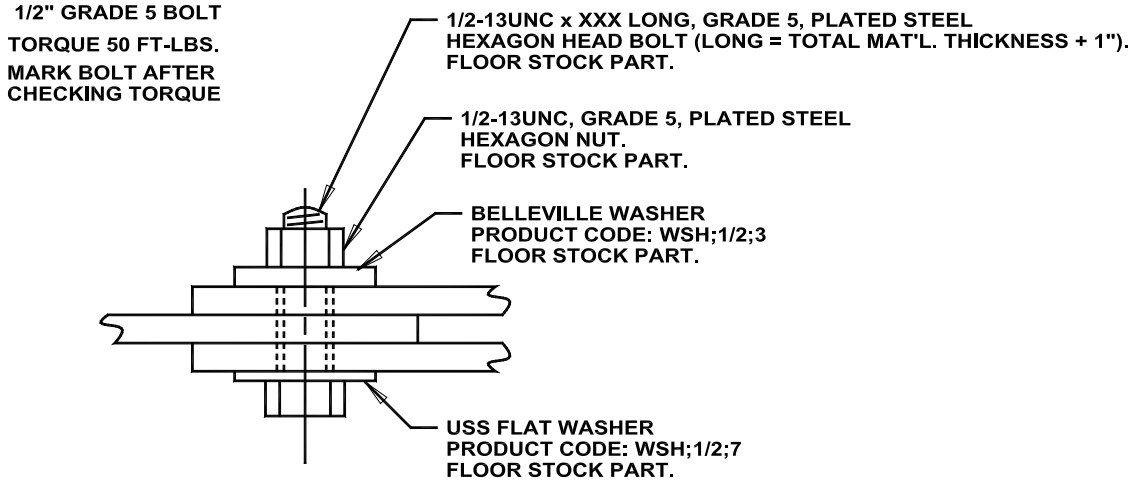
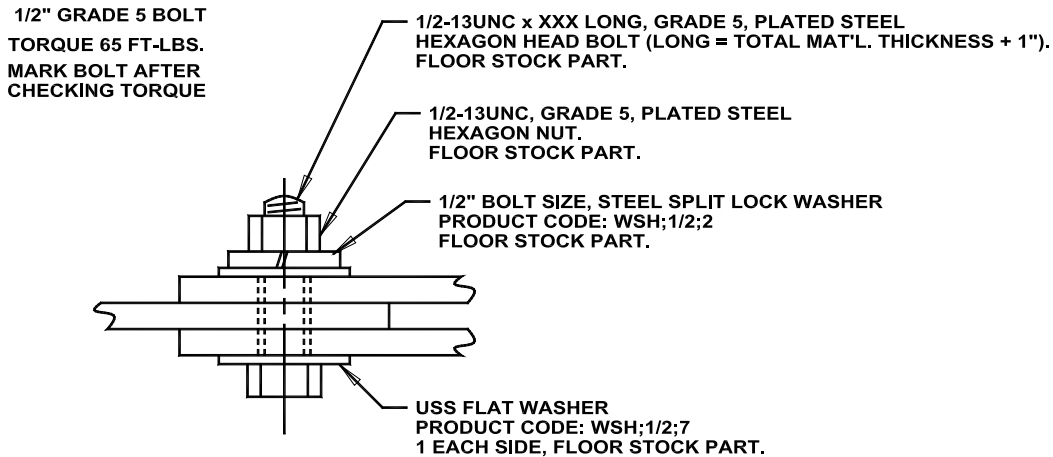
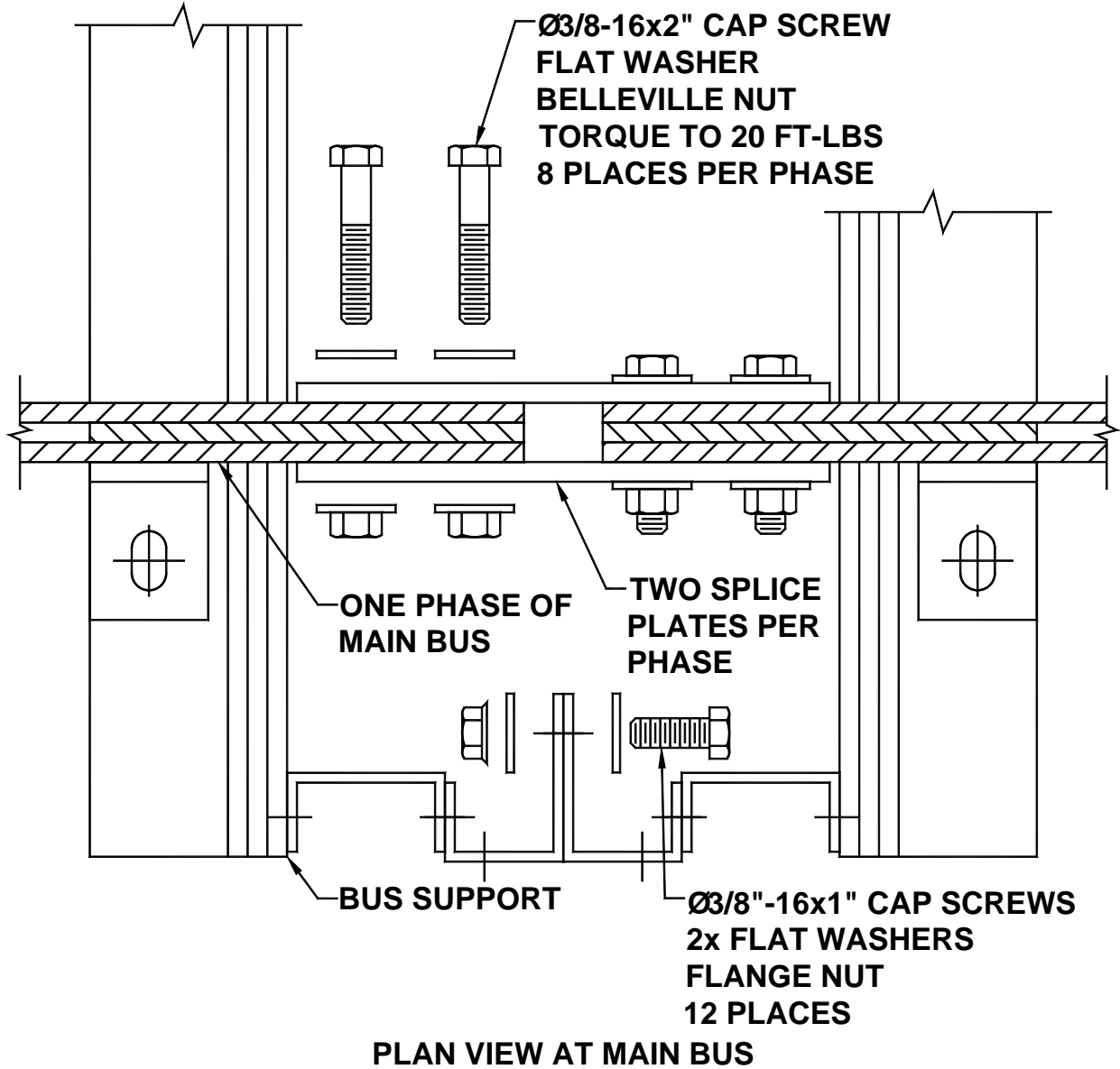

FIG. 6) 1/2" FASTENERS (MEDIUM VOLTAGE)

COPPER ONLY



Drawing No. 099C002



Drawing No. 099C003

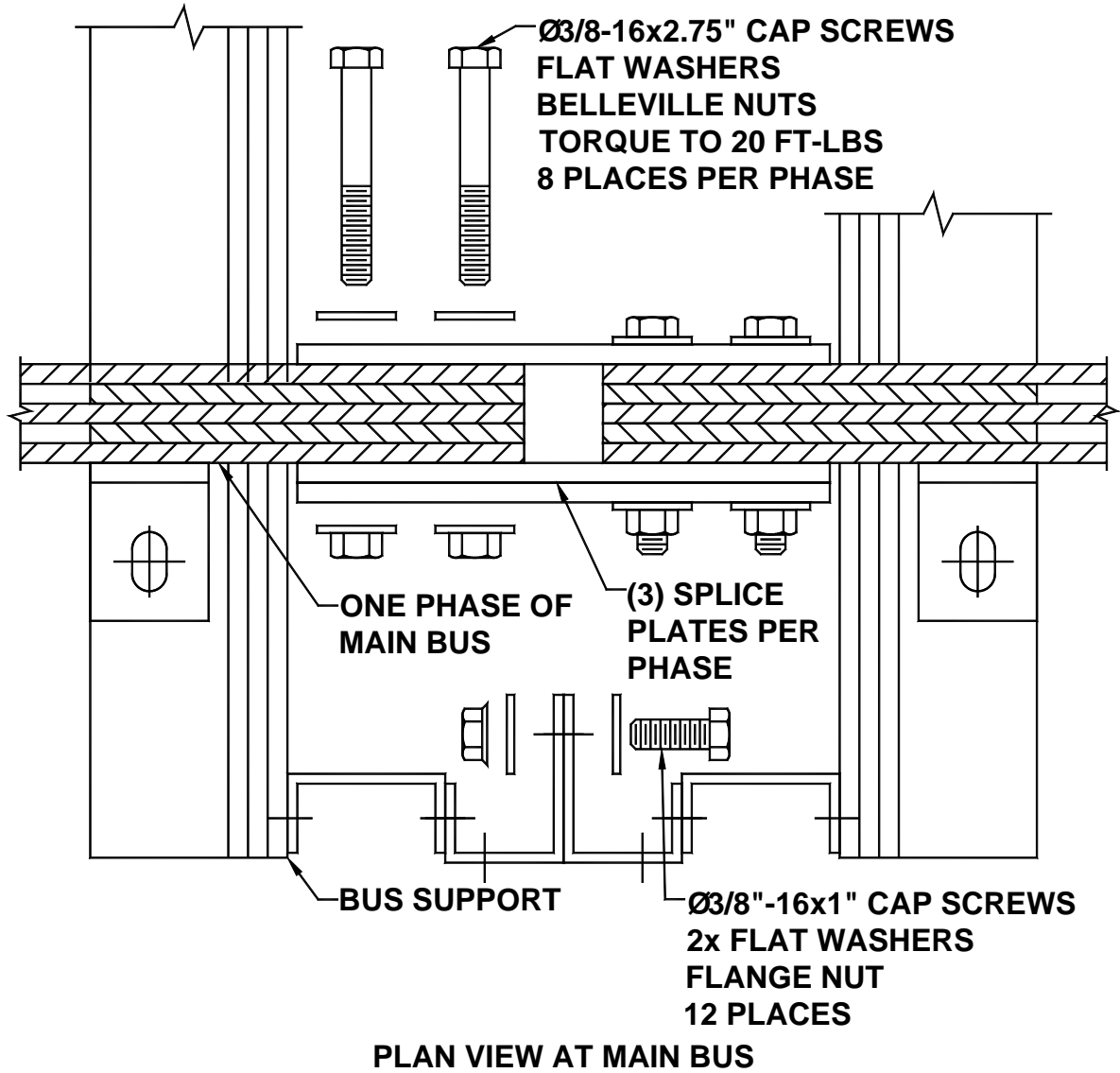

Drawing No. 099C004

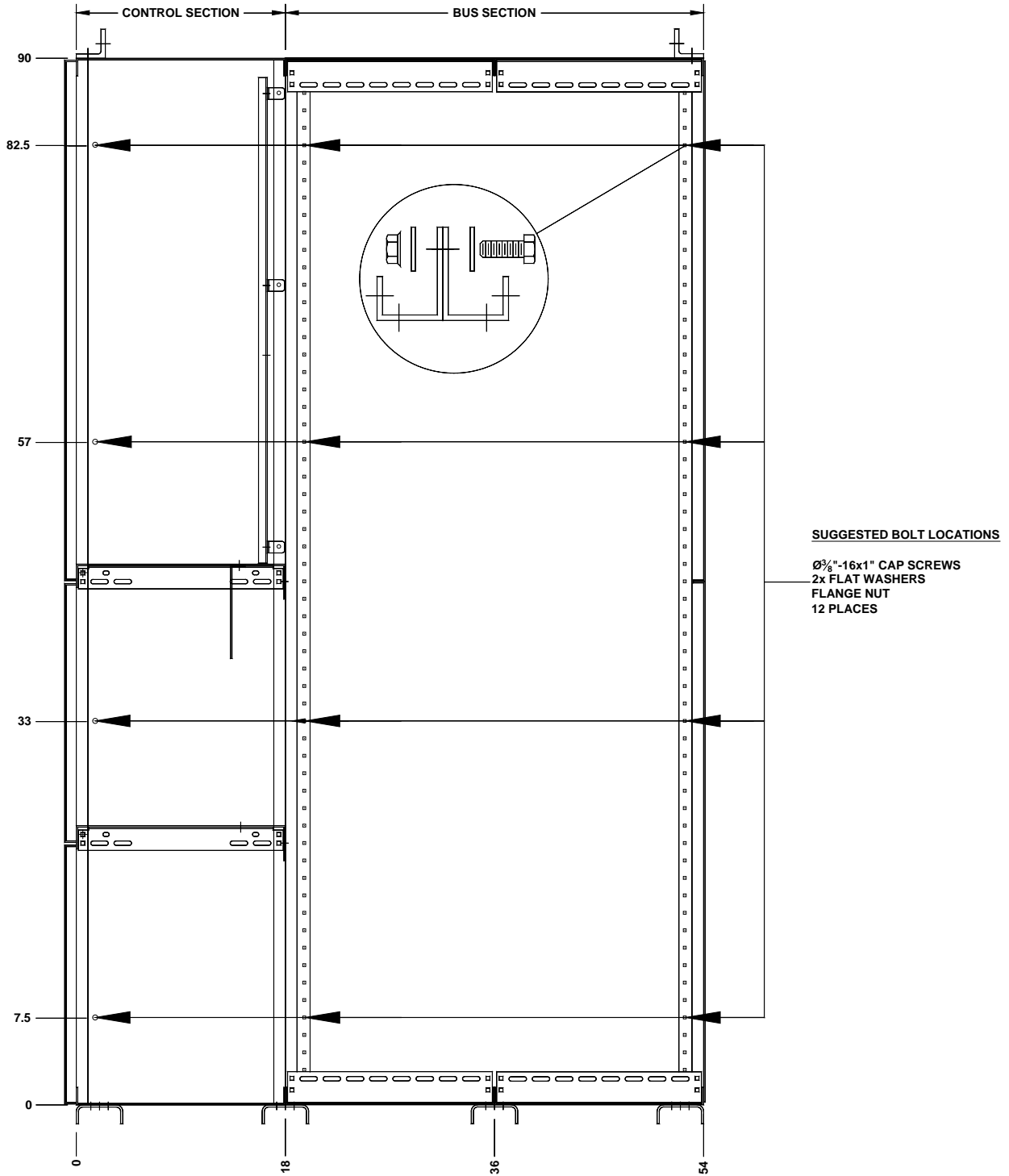

TYPICAL CROSS-SECTION
SERIES 2000 SWITCH GEAR

Drawing No. 099C005

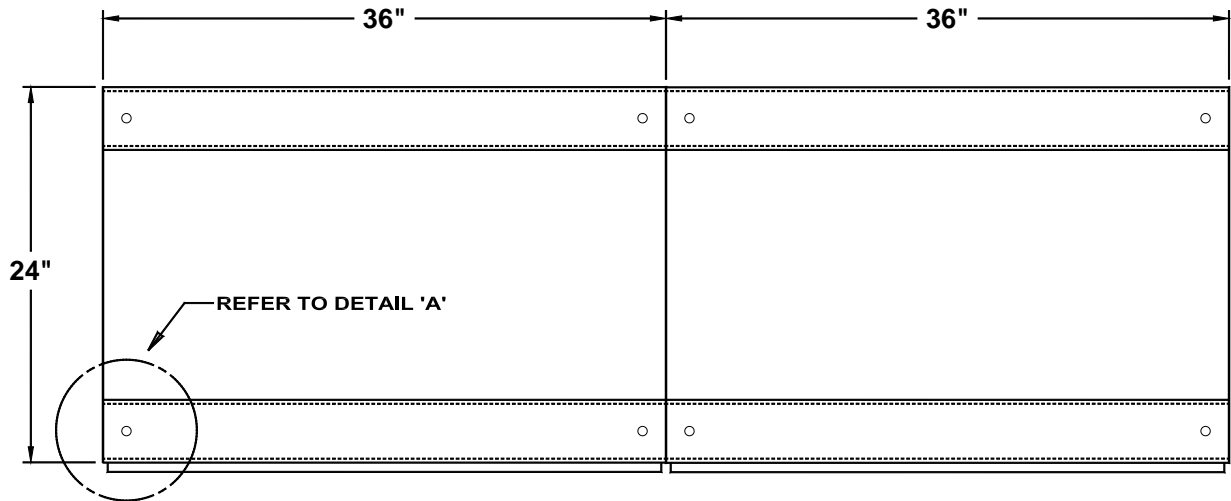

PLAN VIEW OF BASE
(TYPICAL)

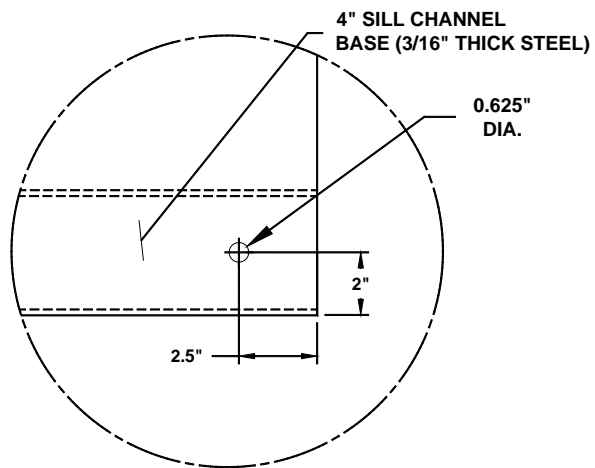

DETAIL 'A'