

# TS 870

## **AUTOMATIC TRANSFER SWITCH WITH TSC 900 CONTROLLER (OPEN & CLOSED TRANSITION)**

### **INSTALLATION, OPERATING & SERVICE MANUAL**

Part #006332



# TABLE OF CONTENTS

<b>1. PRODUCT REVISION HISTORY</b>	<b>4</b>
<b>2. EQUIPMENT STORAGE</b>	<b>5</b>
2.1. EQUIPMENT STORAGE	5
<b>3. NOTES TO INSTALLER</b>	<b>5</b>
3.1. INSTALLATION CODES/PERMITS:	6
3.2. APPLICATION:	6
3.3. INSTALLATION LOCATION:	6
3.4. POWER CABLING:	6
3.5. CONTROL WIRING:	6
3.6. GENERATOR SET AUTOMATIC OPERATION:	7
3.7. LOAD TYPES:	7
3.8. UPSTREAM OVER CURRENT PROTECTION	
(NON-SERVICE ENTRANCE RATED TS 870):	7
3.9. UPSTREAM OVERCURRENT PROTECTION	
(SERVICE ENTRANCE RATED TS870):	7
3.10. WITHSTAND/INTERRUPTING CURRENT RATINGS:	7
3.11. TRANSFER SWITCHES WITH INTEGRAL OVER CURRENT PROTECTION	8
3.12. TRANSFER SWITCHES WITH MULTI-TAP VOLTAGE CAPABILITY	8
3.13. REMOTE START CONTACT FIELD WIRING	9
3.14. DIELECTRIC TESTING	9
3.15. INSTALLATION OF OPEN TYPE TRANSFER SWITCHES	9
3.16. SEISMIC ANCHORING	9

<b>4. GENERAL DESCRIPTION</b>	<b>13</b>
4.1. TSC 900 ATS CONTROLLER	13
4.2. ATS POWER SWITCHING MECHANISM	14
4.3. PRODUCT MODEL CODE	18
4.4. TYPICAL COMMISSIONING PROCEDURES	19
<b>5. AUTOMATIC SEQUENCE OF OPERATION</b>	<b>19</b>
5.1. STANDARD ATS - OPEN TRANSITION	19
5.2. STANDARD ATS - CLOSED TRANSITION	20
5.3. DUAL SOURCE ATS	23
5.4. SERVICE ENTRANCE RATED ATS	25
5.5. TEST MODES	30
<b>6. OVER CURRENT PROTECTION</b>	<b>31</b>
6.1. STANDARD TS 870 AUTOMATIC TRANSFER SWITCH	31
6.2. OPTIONAL TS 870 AUTOMATIC TRANSFER SWITCH WITH INTEGRAL OVER CURRENT PROTECTION	31
<b>7. GENERAL NOTES ON SERVICING TRANSFER SWITCH MECHANISMS</b>	<b>33</b>
<b>8. ATS MANUAL OPERATING INSTRUCTIONS</b>	<b>35</b>
8.1. S-STYLE ATS -MANUAL OPERATION	35
8.2. T-STYLE ATS -MANUAL OPERATION	37
8.3. MO STYLE ATS -MANUAL OPERATION	39
<b>9. FRONT VIEW (TYPICAL) 3 / 4 POLE 100A-250A S-STYLE TRANSFER MECHANISM</b>	<b>47</b>
<b>10. FRONT VIEW (TYPICAL) 3 POLE 400A-800A S-STYLE TRANSFER MECHANISM (MECHANISM FRONT COVER REMOVED)</b>	<b>48</b>
<b>11. FRONT VIEW (TYPICAL) 3 / 4 POLE MOTOR OPERATOR (MO) STYLE TRANSFER MECHANISM (400A-800A CLOSED TRANSITION, 1000-1200A)</b>	<b>49</b>
<b>12. CABLE TERMINAL INFORMATION</b>	<b>50</b>



<b>13. REQUIREMENTS FOR UPSTREAM CIRCUIT PROTECTIVE DEVICES</b>	<b>51</b>
13.1. WITHSTAND CURRENT RATINGS (ALL MODELS WITHOUT INTEGRAL OVERCURRENT PROTECTION OPTION)	51
13.2. INTERRUPTING CAPACITY CURRENT RATINGS (ALL MODELS WITH INTEGRAL OVERCURRENT PROTECTION OPTION)	52
<b>14. GROUND FAULT SITE TEST REQUIREMENTS</b>	<b>52</b>
14.1. PERFORMANCE TEST	52
<b>15. TROUBLESHOOTING</b>	<b>53</b>
<b>16. REPLACEMENT PARTS</b>	<b>58</b>
<b>17. PRODUCT RETURN POLICY</b>	<b>60</b>
<b>18. NOTES</b>	<b>61</b>
<b>19. PERFORMANCE TEST FORM</b>	<b>62</b>
<b>APPENDIX A – TYPICAL TS 870 ATS COMMISSIONING PROCEDURE</b>	
<b>APPENDIX B – TS 870 SYSTEM VOLTAGE CHANGE PROCEDURE</b>	
<b>APPENDIX C –SEISMIC CERTIFICATE</b>	





## 1. PRODUCT REVISION HISTORY

The following information provides an historical summary of changes made to this product since the original release.

### Operating & Service Manual Version

<b>Rev 0</b> 04/11/19	Original release.
<b>Rev 1</b> 05/03/08	Changes to incorporate reversing style ATS Motor for 100-250A transfer switches.
<b>Rev 2</b> 05/05/26	Revisions to <a href="#">Section 8</a> and <a href="#">Section 18</a> .
<b>Rev 3</b> 06/05/08	Revisions to <a href="#">Section 15</a> .
<b>Rev 4</b> 07/07/31	Changes to Incorporate new S-Style 400A mechanism
<b>Rev 5</b> 08/03/05	Changes to Incorporate new S-Style mechanism (100A, 150A, 200A, 250A, 600A, 800A)
<b>Rev 6</b> 08/08/01	Changes to Incorporate optional TSC 80e Transfer Controller
<b>Rev 7</b> 09/01/01	Changes to Incorporate standard TSC 80e Transfer Controller
<b>Rev 8</b> 10/01/25	Changes to Incorporate Seismic Certification and Mounting Requirements
<b>Rev 9</b> 14/01/08	Update to Marathon Thomson Power System Logo
<b>Rev 10</b> 15/04/07	Changes to incorporate TSC 900 Transfer Switch Controller
<b>Rev 11</b> 16/04/19	Added Closed Transition Transfer models, and Motor Operator Style ATS mechanisms

Contact Thomson Power Systems, to obtain applicable instruction manuals or if in doubt about any matter relating to installation, operation or maintenance. Soft copy of the most current version is available at [www.thomsonps.com](http://www.thomsonps.com).

**NOTE:** All information contained in this manual is for reference only and is subject to change without notice.





## Related Product Instruction Manuals

- TS 870 Quick Start Instruction Manual, PM150
- TSC 900 Transfer Switch Controller, PM151
- TSC 900 Modbus™ Communication, PM152

Contact Thomson Power Systems, to obtain these instruction manuals. Soft copy of the most current versions of these manuals are available at [www.thomsonps.com](http://www.thomsonps.com).

## 2. EQUIPMENT STORAGE

The following procedures are required for correct storage of the transfer switch prior to installation.

### CAUTION

**Failure to store and operate equipment under the specified environmental conditions may cause equipment damage and void warranty.**

### 2.1. EQUIPMENT STORAGE

The transfer switch shall be stored in an environment with a temperature range not exceeding -4° to +158° Fahrenheit (-20° to +70° Celsius) and a humidity range not exceeding 5%-95% non-condensing. Before storing, unpack sufficiently to check for concealed damage. If concealed damage is found, notify the ATS supplier and the Carrier immediately. Repack with the original, or equivalent packing materials. Protect from physical damage. Do not stack. Store indoors in a clean, dry, well ventilated area free of corrosive agents including fumes, salt and concrete/cement dust. Apply heat as necessary to prevent condensation.

## 3. NOTES TO INSTALLER

### DANGER

**Arc Flash and Shock Hazard. Will cause severe injury or death.**

**Do not open equipment until ALL power sources are disconnected**

**This equipment must be installed and serviced only by qualified electrical personnel utilizing safe work practices and appropriate Personal Protective Equipment (PPE). Failure to do so may cause personal injury or death**





### **3.1. INSTALLATION CODES/PERMITS:**

Suitable permits are required by local authorities having jurisdiction prior to installing standby generator sets and automatic transfer switches.

### **3.2. APPLICATION:**

The TS 870 Transfer Switch is Listed by Underwriters Laboratories (UL) to Safety Standard UL 1008 for Transfer Switches for Emergency Standby applications. This product is intended for installation and operation on legally required standby applications for emergency power systems as defined by the National Electrical Code (NEC).

### **3.3. INSTALLATION LOCATION:**

The standard TS 870 transfer switch is designed for indoor wall mounting or outdoor wall mounting with NEMA 3R rating. The transfer switch must be installed in an environment where the temperature range is within +5° to +122° Fahrenheit (-15° to +50° Celsius) and humidity range not exceeding 5%-95% non-condensing.

**NOTE:** The transfer switch must not be installed in a location where it is subjected to direct sunlight on the front of the transfer switch door. In these applications, an optionally available sun-shade kit must be installed.

### **3.4. POWER CABLING:**

All power cabling entering/exiting the enclosure must be installed in suitably sized conduit per NEC/CEC requirements. Ampacity, type and voltage rating of current carrying conductors must also comply with NEC/CEC requirements and local authorities having jurisdiction. To ensure satisfactory installation of this equipment, refer to manual [SECTION 15](#) Cable Terminal Information regarding power cable connection tightness requirements. All mechanical and electrical connections must be checked for tightness prior to placing this equipment in service to ensure proper operation and to validate applicable warranty coverage.

### **3.5. CONTROL WIRING:**

All control wiring for engine start, load shed, alarm and remote test must be installed in separate conduits from all power cabling and must utilize suitably sized conduits per NEC/CEC requirements. All control wiring shall be sized for minimum #18 AWG. Control wiring type and voltage rating must also comply with NEC/CEC requirements and local authorities having jurisdiction.

**NOTE:** All field wiring/communication cabling that may be field installed directly onto any ATS door mounted components must be suitably routed and protected across the door hinge to prevent possible mechanical damage upon door opening and/or door closing.







### **3.6. GENERATOR SET AUTOMATIC OPERATION:**

The TS 870 transfer switch operates in conjunction with any generator set with remote automatic starting capabilities utilizing a 2 wire, remote start control contact input. A dry contact is provided for remote generator starting control (contact closes to start generator and opens to stop generator).

### **3.7. LOAD TYPES:**

The standard TS 870 is suitable for control of motors, electric discharge lamps, tungsten filament lamps, and electric heating equipment where the sum of motor full-load ampere ratings and the ampere ratings of other loads do not exceed the ampere rating of the switch and the tungsten load does not exceed 30 percent of the switch rating.

### **3.8. UPSTREAM OVER CURRENT PROTECTION (NON-SERVICE ENTRANCE RATED TS 870):**

Non-Service Entrance Rated TS 870 transfer switch models do not contain any integral over current protection and require upstream over current protection devices for both Utility and Generator sources.

### **3.9. UPSTREAM OVERCURRENT PROTECTION (SERVICE ENTRANCE RATED TS870):**

Service Entrance rated TS 870 transfer switch models contain integral over current protection for the Utility source as standard. Service Entrance rated TS 870 transfer switches do not contain any integral over current protection for the generator source and requires upstream generator source over current protection. The Service Entrance rated TS 870 is rated for 80% maximum continuous loading of load types as described per [SECTION 3.7](#).

### **3.10. WITHSTAND/INTERRUPTING CURRENT RATINGS:**

Refer to electrical ratings shown in [SECTION 16](#) for withstand/Interrupting current ratings. Short circuit currents listed for Standard type ATS are Withstand ratings. Short circuit currents listed for Service Entrance type ATS are Interrupting ratings based on the ratings of the supplied utility service disconnect circuit breaker utilized.





### 3.11. TRANSFER SWITCHES WITH INTEGRAL OVER CURRENT PROTECTION

For models of transfer switch with integral over current protection, the over current protection must be set prior to operation. The equipment will be shipped from the factory with a long-time current setting of 100% (of the equipment rating) and maximum short-time/instantaneous current and time delay settings.

#### WARNING

**Do Not Energize this equipment until device settings have been verified to ensure proper system protection & coordination. Failure to do so may result in equipment failure.**

Refer to **SECTION 5.2.2** of this manual for additional information on operation of the Transfer switch following an over current trip condition. Refer to information supplied with the transfer switch documentation package for adjustment procedures on the power switching units over current protection trip unit. Contact the factory if any additional information is required.

### 3.12. TRANSFER SWITCHES WITH MULTI-TAP VOLTAGE CAPABILITY

If the transfer switch has programmable multi-tap voltage capability (i.e. ATS Model Code with Voltage Code “Y”), confirm the transfer switch has been configured for the correct system voltage prior to installation.

#### WARNING

**Failure to confirm and match transfer switch voltage with the system voltage could cause serious equipment damage.**

The voltage selections and connections are shown on the drawings supplied with each transfer switch. The factory default settings will be indicated on the calibration label attached on the inside of the enclosure door (supplied loose on open style models). A blank label is included to record the applicable settings if the configuration is changed from the factory default settings.

To change the transfer switch voltage, refer to TS 870 System Voltage Change Procedure, Appendix B. Contact Thomson Power Systems for further information as may be required.





### **3.13. REMOTE START CONTACT FIELD WIRING**

As a minimum, the remote engine start control field wiring shall conform to the local regulatory authority on electrical installations. Field wiring of a remote start contact from a transfer switch to a control panel should conform to the following guidelines to avoid possible controller malfunction and/or damage.

- 3.5.1.** Minimum #14 AWG (2.5mm<sup>2</sup>) wire size shall be used for distances up to 100ft (30m)<sup>1</sup>. For distances exceeding 100 ft. (30m) consult Thomson Power Systems
- 3.5.2.** Remote start contact wires should be run in a separate conduit.
- 3.5.3.** Avoid wiring near AC power cables to prevent pick-up of induced voltages.
- 3.5.4.** An interposing relay may be required if field-wiring distance is excessively long (i.e. greater than 100 feet (30m)) and/or if a remote contact has a resistance of greater than 5.0 ohms.
- 3.5.5.** The remote start contact must be voltage free (i.e. dry contact). The use of a powered contact will damage the transfer controller.

### **3.14. DIELECTRIC TESTING**

Do not perform any high voltage dielectric testing on the transfer switch with the TSC 900 controller connected into the circuit as serious damage will occur to the controller. All AC control fuses and control circuit isolation plugs connected to the TSC 900 must be removed if high voltage dielectric testing is performed on the transfer switch.

### **3.15. INSTALLATION OF OPEN TYPE TRANSFER SWITCHES**

Please refer to the factory for additional information.

### **3.16. SEISMIC ANCHORING**

Model TS870 Automatic Transfer Switches and Automatic Transfer and Bypass Isolation Switches in "standard" enclosures are seismic certified under AC156 building code for non-structural components.

Standard enclosures are all transfer switch enclosures Thomson Power Systems offers in NEMA 1, NEMA 2, NEMA 3R and NEMA 4X for the above listed product.

The transfer switch must be installed per the anchoring details provided for seismic qualification. The equipment can be mounted in alternate means and still qualify if a qualified Civil Engineer designs the alternate method of anchoring.



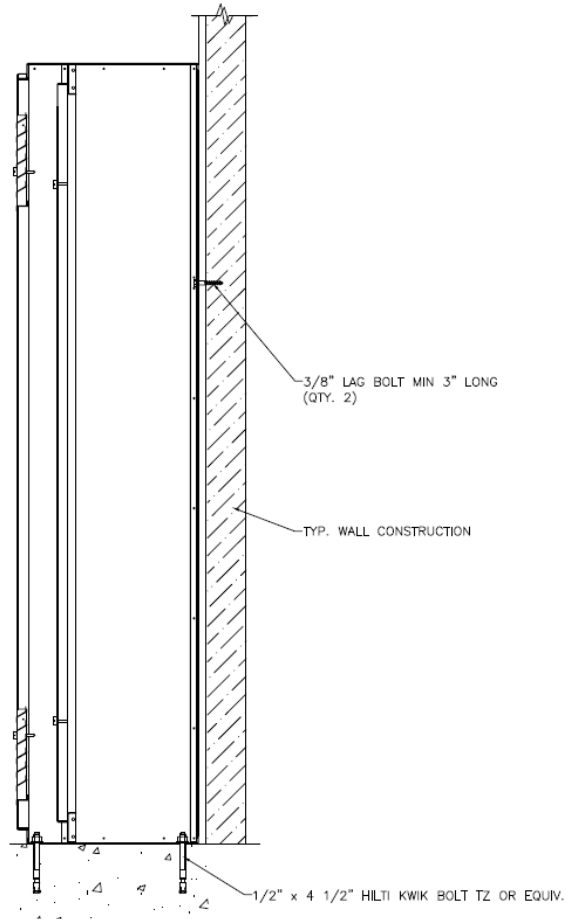

TYP. FLOOR/WALL ANCHORING  
(REFER TO NOTE 5)



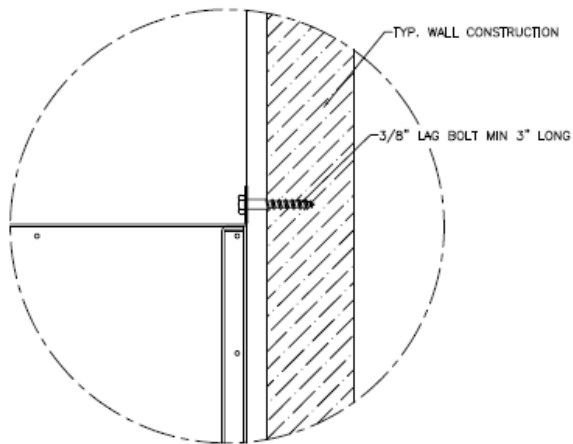

TYP. WALL ANCHORING

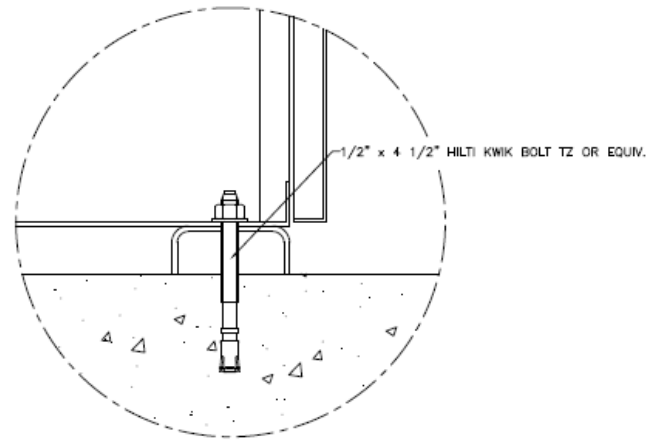

TYP. FLOOR ANCHORING





### **Anchoring Notes:**

1. Anchoring must be designed according to IBC 2012 or latest version.
2. The anchoring details shown are recommended according to the seismic certification; design Engineer may use alternate anchors within the scope of IBC.
3. Wall anchors in concrete; use a typical concrete anchor as necessary.
4. Expansion anchors as shown. To be installed according to manufacturer's recommendation.
5. The 800-1200A NEMA 3R ATS enclosure may be floor/wall mounted or it may be free standing (floor mounted only); If free standing it must be a minimum of 12" (305mm) away from pipes, conduits or other obstructions to allow for sway during a seismic event.





For further information on the TSC 900 Transfer Controller, refer to separate instruction manual PM151.

## 4.2. ATS POWER SWITCHING MECHANISM

Four types of ATS power switching mechanisms are provided with TS 870 Series ATS based on amperage size and optional features supplied with the ATS as described below.

### 4.2.1. “S”- STYLE ATS MECHANISM (100A-800A, OPEN TRANSITION)

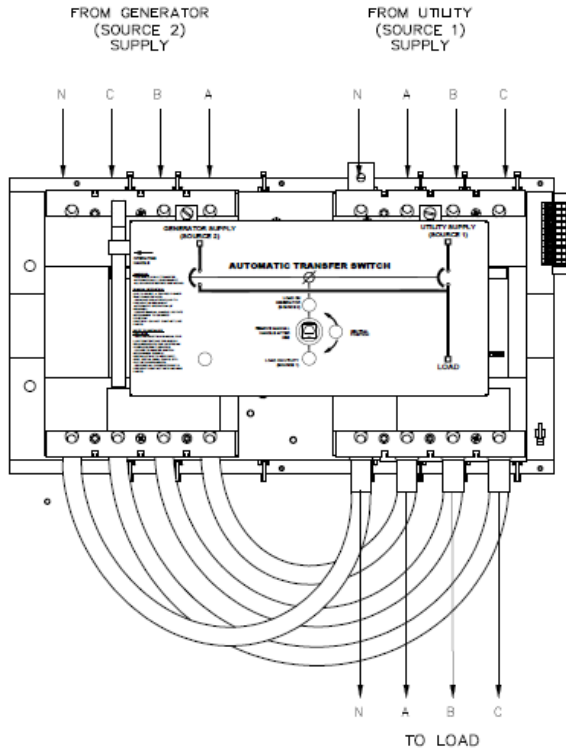

The ATS mechanism consists of 2 power switching devices which are mounted in a horizontal (i.e. side-by-side) configuration. The ATS mechanism provides a positive mechanical interlock to prevent both power switching units from being closed at the same time. The ATS mechanism utilizes a single 120VAC reversible gear motor drive which is mounted in between the two power switching devices. The transfer switch gear motor utilizes the power from the source to which the electrical load is being transferred. The gear motor drives a common drive hub assembly which in-turn operates the power switching device toggles via independent operating arms. Two limit switches are utilized to disconnect control power to the gear motor once correct operating positions are reached.

On 100-250A transfer mechanisms, the load-side of the power switching devices are interconnected via power cable. On 400-800A transfer mechanisms, the load-side of the power switching devices are interconnected via bus bars. The TSC 900 transfer controller provides a standard neutral position delay timer to allow adequate voltage decay during transfer operation to prevent out of phase transfers





### 4.2.1. "T"- STYLE ATS MECHANISM (1000A-1200A, OPEN TRANSITION)

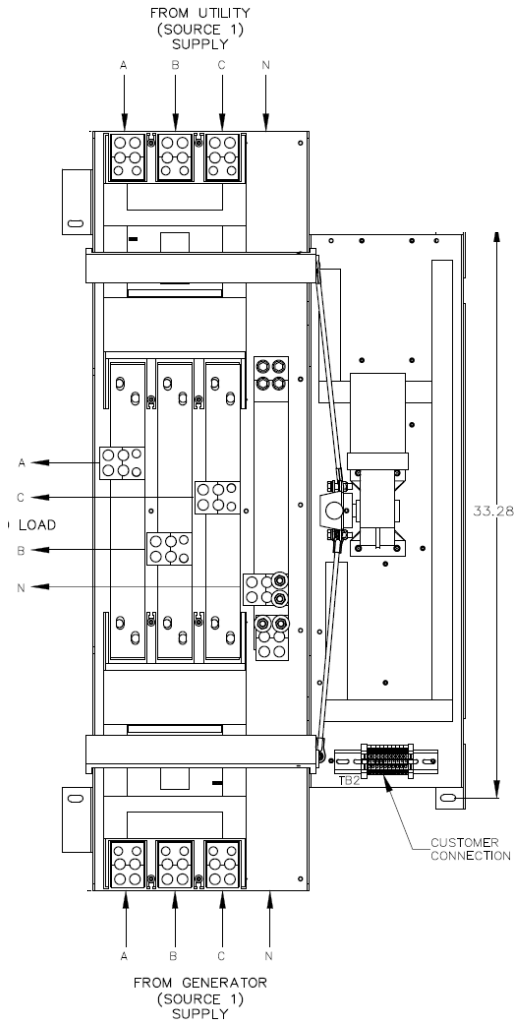

The ATS mechanism consists of 2 power switching devices which are mounted in a vertical stacked configuration. The ATS mechanism provides a positive mechanical interlock to prevent both power switching units from being closed at the same time. The ATS mechanism utilizes a single 120VAC reversible gear motor drive which is mounted in between the two power switching devices. The transfer switch gear motor utilizes the power from the source to which the electrical load is being transferred. The gear motor drives a common drive hub assembly which in-turn operates the power switching device toggles via independent operating arms. Two limit switches are utilized to disconnect control power to the gear motor once correct operating positions are reached. The TSC 900 transfer controller provides a standard neutral position delay timer to allow adequate voltage decay during transfer operation to prevent out of phase transfers.





### 4.2.2. MO- STYLE ATS MECHANISM (400A-800A CLOSED TRANSITION)

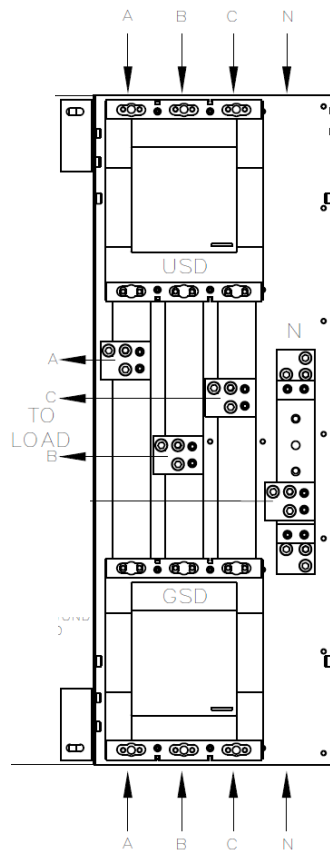

The ATS mechanism consists of 2 power switching devices which are mounted in a vertical stacked configuration. Each power switching device uses a 120VAC motor operator with individual spring charging mechanism and shunt trip/close coils. The transfer switch mechanism utilizes the power from the source to which the electrical load is being transferred to.

The Closed Transition transfer feature allows a make-before-break transfer sequence when both sources of power are available. For Closed Transition operation, the TSC 900 transfer controller provides in-phase closing protection to ensure all transfers are in synchronism prior to closing.





### 4.2.3. MO- STYLE ATS MECHANISM (1000A-1200A OPEN & CLOSED TRANSITION)

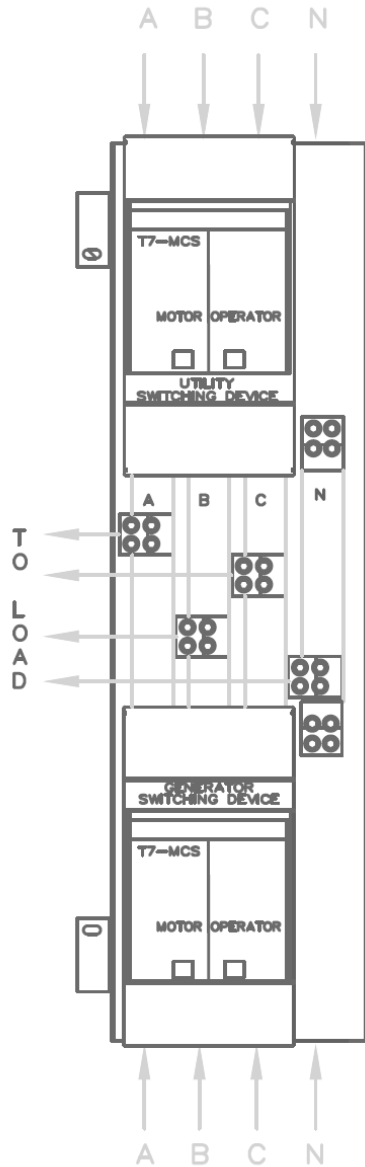

The ATS mechanism consists of 2 power switching devices which are mounted in a vertical stacked configuration. Each power switching device uses a 120VAC motor operator with individual spring charging mechanism and shunt trip/close coils. The transfer switch mechanism utilizes the power from the source to which the electrical load is being transferred to. Open Transition type transfer switches are equipped with a cable interlock mechanism to prevent both power switching devices being closed at the same time.

Closed Transition type transfer switches allow a make-before-break transfer sequence when both sources of power are available. For Closed Transition operation, the TSC 900 transfer controller provides in-phase closing protection to ensure all transfers are in synchronism prior to closing.



### 4.3. PRODUCT MODEL CODE

The type of TS 870 series transfer switch supplied is identified by way of a 21 digit product code which appears on the equipment rating plate, or model, on the door of the transfer switch, and on the transfer switch drawings. The model code structure and definitions are as follows:

	1	2		4	5	6	7	8	9	10	11	12	13	14	15	16	17	18	19	20	21
	T	S		8	7																

<p><b>1-3. SERIES</b> TS - TRANSFER SWITCH</p> <p><b>4 &amp; 5. MODEL</b> 87 - 870 SWITCH</p> <p><b>6. POLES</b> 2 - 2 POLE 3 - 3 POLE 4 - 4 POLE</p> <p><b>7. CONFIGURATION TYPE</b> A - ATS E - DOUBLE BYPASS - 4 BRKR<sup>9</sup> X - SPECIAL</p> <p><b>8 - 11. AMPERAGE</b> 0100 0150 0200<sup>5</sup> 0250 0400 0600 0800 1000 1200</p> <p><b>12. APPLICATION</b> A - STANDARD B - SERVICE ENTRANCE C - DUAL UTILITY CONTROL D - DUAL STANDBY GEN (Slave ATS) H - DUAL PRIME GEN CONTROL X - SPECIAL</p> <p><b>13. OPERATION TYPE</b> 1 - OPEN TRANSITION 2 - MANUAL ELEC. OP. 3 - CLOSED TRANSITION (MOMENTARY)<sup>7</sup> X - SPECIAL</p> <p><b>14. SAFETY STANDARDS</b> A - UL 1008 (Service Entrance) B - CSA C22.2 NO 178 C - UL 1008 / CSA 178 X - NOT APPLICABLE</p>	<p><b>15. VOLTAGE</b> <b>1Ø 3 WIRE</b> D - 120/240</p> <p><b>3Ø 4 WIRE (GROUNDED NEUTRAL)</b> E - 120/208<sup>1</sup> F - 127/220 G - 120/240<sup>1</sup> (DELTA) H - 220/380<sup>2</sup> S - 230/400<sup>2</sup> J - 240/416 K - 254/440 M - 277/480<sup>1</sup> N - 347/600<sup>1</sup> Y - MULTI-VOLTAGE (STOCK SWITCHES ONLY)<sup>1</sup> <i>Customer Configurable</i></p> <p><b>16. CONTROLLER</b> 5 - TSC 900 c/w GHC Graphic Display 7 - NONE (MANUAL)</p> <p><b>17. ENCLOSURE TYPE</b> A - NEMA1, ASA #61 GRAY B - NEMA2, ASA #61 GRAY C - NEMA12, ASA #61 GRAY D - NEMA3R SD, ASA #61 GRAY E - NEMA3R DD, ASA #61 GRAY F - NEMA3RX/4X DD (304 STAINLESS STEEL)<sup>3</sup> G - NONE (OPEN STYLE) L - NEMA3RX/4X DD (316 STAINLESS STEEL)<sup>3</sup> X - SPECIAL</p>	<p><b>18. UTILITY SWITCHING DEVICE</b> D - MOLDED CASE SWITCH DRAWOUT<sup>9</sup> (400 - 1200A) E - MOLDED CASE SWITCH DRAWOUT<sup>9</sup> C/W ELECTRONIC TRIP (400-1200A) F - MOLDED CASE SWITCH DRAWOUT<sup>9</sup> C/W ELECTRONIC TRIP &amp; GF (400-1200A) K - MOLDED CASE SWITCH (100 - 1200A) M - MOLDED CASE SWITCH C/W THER-MAG TRIP (100-200A) N - MOLDED CASE SWITCH C/W ELECTRONIC TRIP (250-1200A) P - MOLDED CASE SWITCH C/W ELECTRONIC &amp; GF TRIP (250-1200A)</p> <p><b>19. GENERATOR SWITCHING DEVICE</b> D - MOLDED CASE SWITCH DRAWOUT<sup>9</sup> (400 - 1200A) E - MOLDED CASE SWITCH DRAWOUT<sup>9</sup> C/W ELECTRONIC TRIP (400-1200A) F - MOLDED CASE SWITCH DRAWOUT<sup>9</sup> C/W ELECTRONIC TRIP &amp; GF (400-1200A) K - MOLDED CASE SWITCH (100 - 1200A) M - MOLDED CASE SWITCH C/W THER-MAG TRIP (100-200A) N - MOLDED CASE SWITCH C/W ELECTRONIC TRIP (250-1200A) P - MOLDED CASE SWITCH C/W ELECTRONIC &amp; GF TRIP (250-1200A)</p> <p><b>20. POWER CONNECTIONS</b> A - STANDARD B - ATS CONNECTION PLATE 100A-400A C - ATS CONNECTION PLATE 600A-800A D - ATS CONNECTION PLATE 1000A-1200A E - ATS CONNECTION PLATE 100A-400A FOR U&amp;G F - ATS CONNECTION PLATE 600A-800A FOR U&amp;G G - ATS CONNECTION PLATE 1000A-1200A FOR U&amp;G X - SPECIAL</p> <p><b>21. ATS CONNECTION CONFIGURATION</b> A - STANDARD B - ALTERNATE B (400-1200A) C - ALTERNATE C (400-1200A) D - ALTERNATE D (400-1200A)</p> <p><b>NOTES</b> <sup>1</sup> MULTI-VOLTAGE CAPABLE <sup>2</sup> FOR 50 Hz APPLICATION <sup>3</sup> STANDARD ENCLOSURE RATING IS N3RX AT 800A, N4X FOR 1000/1200A AND 600A AND BELOW <sup>5</sup> 240V MAX <sup>7</sup> CLOSED TRANSITION OPTION 400A - 1200A ONLY <sup>9</sup> DOUBLE BY PASS OPTION 400A - 1200A ONLY</p>
---	---	---

#### 4.4. TYPICAL COMMISSIONING PROCEDURES

##### CAUTION

**Commissioning procedures must be performed by qualified personnel only. Ensure the Automatic Transfer Switch (ATS) ATS Power Chassis & Voltage Sensing Isolation Plugs PL12 & PL 15 are disconnected prior to energizing the supply sources. Manually place the transfer switch mechanism in the neutral position prior to applying power. Failure to do so may result in equipment failure or personal injury.**

**NOTE:** The Typical Automatic Transfer Switch Commissioning Procedures Model Series TS 870, Appendix A, is provided for general information only pertaining to typical site installations and applications. Contact Thomson Power Systems for further information as may be required.

### 5. AUTOMATIC SEQUENCE OF OPERATION

#### 5.1. STANDARD ATS - OPEN TRANSITION

When utility supply voltage drops below a preset nominal value (adjustable from 70% to 100% of nominal) on any phase, an engine start delay circuit is initiated and the transfer to utility supply signal will be removed (i.e. contact opening). Following expiry of the engine start delay period (adjustable from 0 to 60 sec.) an engine start signal (contact closure) will be given.

Once the engine starts, the transfer switch controller will monitor the generator voltage and frequency levels. Once the generator voltage and frequency rises above preset values (adjustable from 70% to 95% of nominal), the engine warm-up timer will be initiated. Once the warm-up timer expires (adjustable from 0 to 60 min.), the Transfer to Generator Supply signal (contact closure) will be given to the transfer switch mechanism. The load will then transfer from the utility supply to the generator supply via the motor driven mechanism.

The generator will continue to supply the load until the utility supply has returned. The retransfer sequence is completed as follows: when the utility supply voltage is restored to above the preset values (adjustable from 70% to 95% of nominal) on all phases, a transfer return delay circuit will be initiated. Following expiry of the Utility Return Timer (adjustable from 0 to 60 min.), the Transfer to Generator Supply signal will be removed (contact opening), then the Transfer to Utility Supply signal (contact closure) will be given to the transfer switch mechanism. The ATS will then retransfer the load from the generator supply back to the utility supply.

**NOTE:** A neutral delay timer circuit will delay the transfer sequence in the neutral position (i.e. both power switching devices open) until the neutral delay time period expires.

An engine cooldown timer circuit will be initiated once the load is transferred from the generator supply. Following expiry of the cooldown delay period (adjustable from 0 to 60 minutes), the engine start signal will be removed (contact opening) to initiate stopping of the generator set.

## 5.2. STANDARD ATS - CLOSED TRANSITION

**NOTE:** This section applies only to Closed Transition configured transfer switches.

For transfer switches equipped with the Closed Transition transfer option, the ATS is configured to operate as follows:

Under normal closed transition operating conditions, the transfer switch operates automatically during a failure and restoration of utility power and does not require operator intervention.

When utility supply voltage drops below a preset nominal value (70 - 99% of rated adjustable) on any phase, an engine start delay circuit will be initiated and the transfer to utility supply signal will be removed (i.e. contact opening). Following expiry of the engine start delay period (0 - 60 sec. adjustable) an engine start signal (contact closure) will be given.

Once the engine starts, the transfer switch controller will monitor the generators voltage and frequency levels. Once the generator voltage and frequency rises above preset values (70 – 99% nominal adjustable) a warm up time delay will be initiated. Once the warm up timer (0-60 Min adjustable) expires, the transfer to generator supply signal (contact closure) will be given to the transfer switch mechanism. The load will then transfer from the utility supply (i.e. opening the utility power switching device) to the generator supply (closing the generator power switching device) via motor driven mechanism to complete a “Break-before-make” open transition transfer sequence.

The generator will continue to supply the load until the utility supply has returned and the retransfer sequence is completed as follows: When the utility supply voltage is restored to above the present values (70 - 99% of rated adjustable) on all phases, a re-transfer sequence will be initiated once the Utility Return timer expires. The utility will close its power switching device when it is in synchronism with the generator supply utilizing the TSC 900 in-phase detector. The generator power switching device will immediately trip open approximately 50-100 milliseconds after the utility power switching device closes to complete the make-before-break re-transfer sequence.

An engine cooldown timer circuit will be initiated once the load is transferred from the generator supply. Following expiry of the cooldown delay period (0 - 60 min.



adjustable) the engine start signal will be removed (contact opening) to initiate stopping of the generator set.

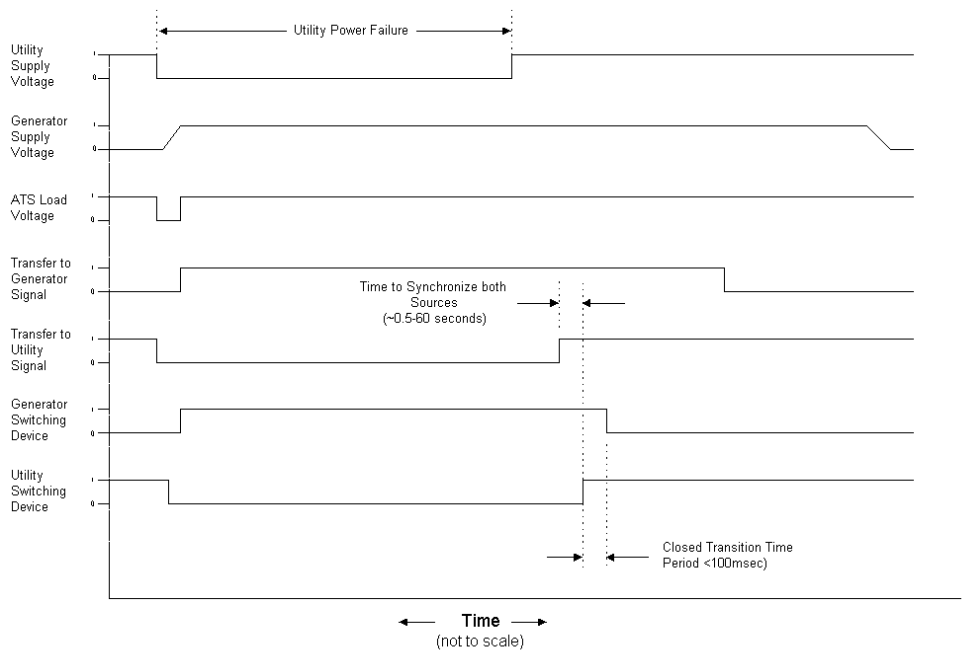

**Closed Transition Operation Sequence Diagram**  
**(Normal Power Failure & Return Sequence)**

The following operating sequences and time delays are associated with closed transition type transfer switches which momentarily parallel two sources of supply for less than 100 milliseconds. For closed transition type transfer switches, which utilize extended parallel operation for soft-loading operating sequences, refer to separate instruction manual.

1. Transfer Control Switch (Open/Closed Transition): A two position selector switch is provided on the front of the transfer switch for operator section of desired operation. The 2 positions are as follows:
  - OPEN TRANSITION: The transfer switch will operate in a “break-before-make” open transition sequence during load transfers. A programmed neutral delay period will occur during the transfer sequence to ensure voltage decays on the load bus before load is re-applied. The two sources will not be paralleled at any time during operation in this mode.





- **CLOSED TRANSITION:** When both sources of supply are available, the transfer switch will operate in a “make-before-break” closed transition sequence during load transfers.

**NOTE:** If only one source of supply is available during an initiated transfer sequence, the control system will automatically revert to an open transition transfer sequence.

2. **Synchronizing Protection:** To ensure both sources are in synchronism prior to initiating a closed transition transfer sequence, a TSC 900 in-phase monitor is used. The GHC has a Sync page to allow monitoring of phase and voltage of the 2 sources. The in-phase relay will block a closed transition transfer sequence until both sources phase angle and voltages are within programmed limits. The synchronizing check relay settings are field programmable (+5 to 20 Deg Phase Angle ( $\Delta\omega$ ) and 1-10% voltage difference ( $\Delta U$ ) and they are factory set as follows:

Factory settings

When the product is delivered from the factory, the following basic settings will be set:

$\Delta U$ :	5% of $\pm U_{BB}$
$t_R$ :	0.5 sec.
$\Delta\phi$ :	$\pm 10^\circ$
Dead bus:	OFF

**NOTE:** The standard closed transition transfer switch does not contain an automatic synchronizer to control the generators frequency or voltage to bring it within limits of the sync check relay. For correct closed transition transfer operation, the system requires the generators frequency to be set within 0.25% of nominal frequency and the generators voltage to be set within 0.5% of nominal voltage.

3. **Closed Transition Time Period:** The time period in which both sources of supply are paralleled together during the closed transition transfer sequence is 50-100 milliseconds (maximum). The time period is inherently controlled by operation of auxiliary contacts from the power switching devices (i.e. when one switching device closes, its aux contact closes to initiate tripping of the opposite switching device).
4. **Closed Transition Failure Mode Operation:** The TSC 900 continually monitors the closed transition operation time period. The TSC 900 is factory set for 100 milliseconds that allows normal closed transition operation (i.e. both power switching devices remain closed for less than 100 milliseconds). The alarm circuit is not activated under normal operation. Should the closed transition operation time exceed 100 milliseconds (i.e. both power switching devices remain closed for longer than the normal closed transition time period plus the setting of TSC 900 timer, the following sequence of events will occur:
  - TSC 900 time delay period will expire and will activate auxiliary trip relay.







- If the transfer switch was transferring power from the generator source to the utility source and the generator switching device failed to open, an auxiliary trip relay will trip open the utility power switching device to immediately separate the two power sources. If the transfer switch was transferring power from the utility source to the generator source and the utility switching device failed to open, an auxiliary trip relay will trip open the generator power switching device to immediately separate the two power sources.

**NOTE:** The maximum time period both sources will remain paralleled under this failure mode is 200 milliseconds.

- The original source (i.e. prior to the transfer sequence) will remain on load, separated from the other source. An alarm light and TSC 900 controller will indicate a failure condition which must be manually reset before the transfer switch will re-attempt subsequent transfers. For further information on the TSC 900 features and operation, refer to the separate product instruction manual.

**NOTE:** Two alarm contacts are provided for the Closed Transition Failure Mode (i.e. one for a failed generator power switching device and one for the utility power switching device. The contacts are for customer use to remotely trip open upstream devices should an abnormal condition persist.

5. **Transfer Fail Alarm (Switching Device Fail to Close):** The TSC 900 provides a timer detect and alarm abnormal operating conditions. Should a power switching device fail to close for any reason within a 5-minute time period, an alarm light and alarm relay contact will be activated. For further information on the TSC 900 features and operation, refer to the separate product instruction manual.

### 5.3. DUAL SOURCE ATS

**NOTE:** This section applies only to Dual Source configured transfer switches.

ATS may be supplied with the following 3 types of optional Dual Source system configurations:

- **DU - Dual Utility ATS:** Used for systems consisting of one ATS connected to two utilities with at least one source continually energized to the ATS. ATS will automatically switch to the alternate source upon failure of the preferred source.
- **DPG - Dual Prime Gen ATS:** Used for systems consisting of one ATS connected to two generators with one generator continually energized to the ATS. ATS will automatically switch to the alternate generator upon failure of the preferred source.
- **DSG - Dual Standby Gen ATS (Slave ATS):** Used for systems consisting of two ATS's in a Master/Slave Configuration. Refer to the following diagram. Only the Slave ATS is to be ordered and configured with the DSG option. The Master ATS is to be ordered as a standard ATS. The Slave ATS will be connected to two



generators which are normally de-energized and are signaled to start from the Master ATS.

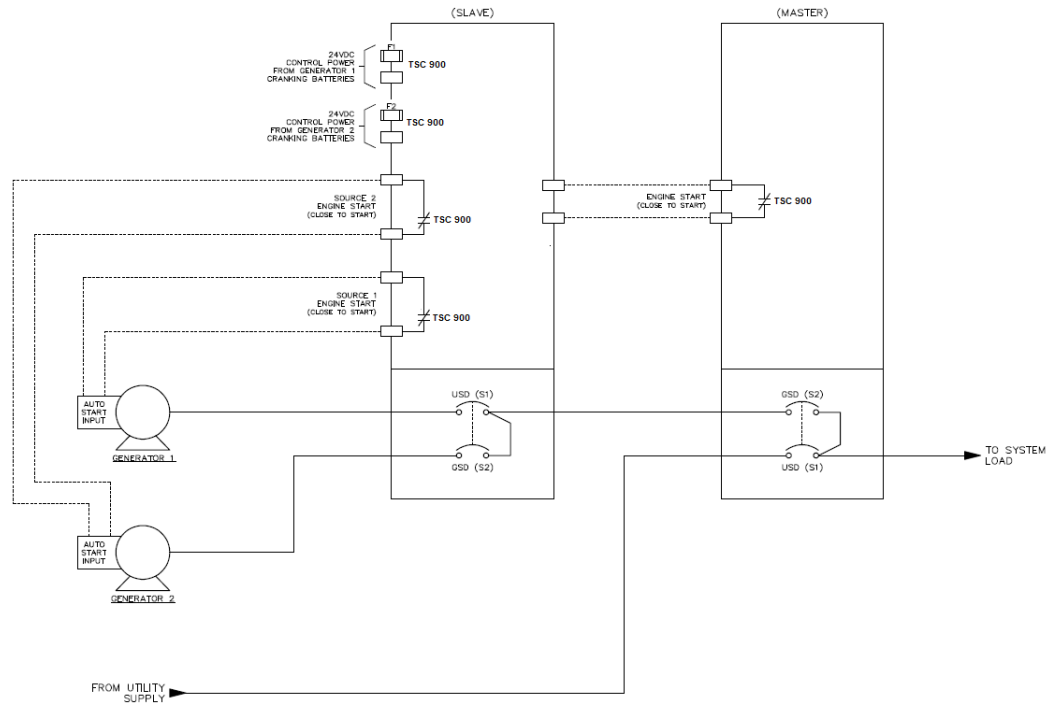

### 5.3.1. DUAL UTILITY ATS

A Dual Utility application allows an operator to select which source is “preferred” (i.e. Either source may be selected as Preferred), therefore, the alternate source will act as the standby source. The Preferred selected source will continuously operate on load. The non-selected preferred source, or standby, will remain off load. The standby source will automatically transfer on load should the Preferred source fail once the Transfer From Preferred Source Delay timer expires. When the Preferred selected source is returned to normal operating status, the load will automatically retransfer back to the Preferred selected source once the Return to Preferred Source Delay timer expires. If the Preferred Source Selector switch is turned to the non-operating source, the load will automatically transfer to this new Preferred source once the Transfer From Preferred Source Delay timer expires.

### 5.3.2. DUAL PRIME GENERATOR ATS

A Dual Prime Generator application allows an operator to select which generator is preferred (i.e. Either generator may be selected as Preferred), therefore, the alternate generator will act as the standby source. The Preferred selected generator will continuously operate on load with an engine start signal maintained. The non-selected preferred generator, or standby, will remain off load. The standby generator will be signaled to automatically start the engine and transfer on load (following its warm up delay period) should the Preferred generator fail once the Transfer From Preferred

Source Delay timer expires. When the Preferred selected generator is returned to normal operating status, the load will automatically retransfer back to the Preferred selected generator once the Return to Preferred Source Delay timer expires. If the Preferred Source Selector switch is turned to the non-operating generator, the load will automatically transfer to this new Preferred generator once the Transfer From Preferred Source Delay timer expires. The originally selected Preferred unit will continue to operate for its cool down period then stop. An automatic Engine Run-Hour balancing program is provided for configuration/use in the Dual Prime Mode. When enabled it will automatically start/stop and transfer each engine (generator set) on/off load to try to balance engine running hours as stored in memory. Refer to TSC 900 Instruction manual for detailed programming instructions.

### 5.3.3. DUAL STANDBY GENERATOR ATS

Under normal Utility Power operation, power to the load will be fed from the Master ATS via closed Utility power switching device. The Dual Standby (Slave) ATS remains de-energized with both generators stopped. Should the utility power fail, the Master ATS will send a common gen start signal to the Dual Standby ATS. The Dual Standby ATS will then send a start signal to one or both generator sets (programmable) to start. The Dual Standby ATS will transfer to the Preferred selected generator position. Once generator voltage is established back to the Master ATS, the load will automatically transfer onto the operating generator. The Standby Gen will automatically stop if selected to do so. The Preferred selected generator will be continuously connected to the load via the Master ATS until Utility Power is re-established. Should the Preferred generator fail while on load, the standby selected generator set will automatically start and the load will be automatically transferred to the standby generator. When the utility power returns to normal, the Master ATS will transfer the load back to the utility supply and will send a signal to the Dual Standby ATS to stop the operating generator. The operating generator unit will continue to run for its cool down period then stop. An automatic Engine Run-Hour balancing program is provided for configuration/use in the Dual Prime Mode. When enabled it will automatically start/stop and transfer each engine (generator set) on/off load to try to balance engine running hours as stored in memory. Refer to TSC 900 Instruction manual for detailed programming instructions.

## 5.4. SERVICE ENTRANCE RATED ATS

**NOTE:** This section applies only to Service Entrance configured transfer switches.

### 5.4.1. NORMAL OPERATION

Under normal conditions, the load is energized from the utility supply through the closed utility transfer power switching device. If the utility power fails, the generator will start and the load will be re-energized via the closed generator transfer power switching device. In the normal operating mode, the Service Disconnect switch shall be in the energized position.



### 5.4.2. OVER CURRENT TRIP

Should the utility power switching device trip open due to an over current condition, TSC 900 transfer controller will initiate an engine start signal and will permit transfer of the load to the generator supply provided the TSC 900 is programmed for Forced Transfer. The utility source will be locked out and the load will remain on the generator supply until the TSC 900 alarm signal is manually reset.

Refer to the TSC 900 Instruction Manual for further details on Transfer Fail/Force Transfer operation.

Should the generator power switching device trip open due to an over current condition, TSC 900 transfer controller will initiate transfer of the load to the utility supply provided the TSC 900 is programmed for "Forced Transfer". The generator source will be locked out and the load will remain on the utility supply until the TSC 900 alarm signal is manually reset.

### 5.4.3. SERVICE DISCONNECT PROCEDURE

To perform a service disconnect (i.e. to disconnect the utility and generator supplies), the following procedure is required:

1. Move the Service Disconnect control switch located on the door of the transfer switch to the Transfer to Neutral position and wait 2 seconds for the ATS to complete a transfer to the neutral position.
2. Once the ATS has transferred to the neutral position, move the Service Disconnect control switch to the Disconnected position.
3. Verify that the Service Disconnected pilot light is illuminated. If the Light is illuminated, the service has been successfully disconnected and it is safe to perform any maintenance procedures as required. In this condition, the transfer switch is in the neutral position, with both utility and generator transfer power switching devices open. The transfer switch will remain in this condition, regardless of condition of the utility and generator supplies.

**NOTE:** If the Service Disconnect Light is not illuminated, additional procedures are required (refer to the following procedure #5.2.4).

4. Attach safety lockout padlock to the "Service Disconnect" control switch to prevent unauthorized change in operating condition and verify transfer switch door is locked closed. If the door is not locked, turn and remove door key.

**WARNING**



**Close and lock the transfer switch enclosure door before connecting power sources.**

5. To re-energize the load, remove the padlock(s) from the service disconnect control switch, and move the switch to the Energized position. The transfer switch will immediately return to the utility or generator supply if within normal operating limits.

#### **5.4.4. ADDITIONAL SERVICE DISCONNECT PROCEDURES (S-STYLE 100A-800A OPEN TRANSITION MECHANISM)**

If the Service Disconnected pilot light is not illuminated, the service will not have been successfully disconnected and therefore it is not safe to perform any maintenance until the following additional procedures are performed:

#### **DANGER**

**Arc Flash and Shock Hazard. Will cause severe injury or death. Do not open equipment until ALL power sources are disconnected.**

**This equipment must be installed and serviced only by qualified electrical personnel utilizing safe work practices and appropriate Personal Protective Equipment (PPE). Failure to do so may cause personal injury or death.**

1. Open the door to the transfer switch using a suitable tool and opening the door lock with the key.
2. Visually inspect the actual position of the transfer switch mechanism. If the position of the transfer switch mechanism is clearly in the neutral position and the load bus is de-energized on all phases, the service has been successfully disconnected. Proceed to Step. 4.

If the position of the transfer switch mechanism is not in the neutral position or the load bus is energized, further procedures are required.

**NOTE:** If the position of the transfer switch mechanism is clearly in the Neutral position, the Service Disconnected pilot light may not have illuminated due to the following reasons:

- a) Utility and generator supply voltages are not present (the TSC 900 requires AC supply voltage to be present to power the pilot light).
- b) The pilot light may be burnt out. The bulb should be immediately replaced with a 6Vdc rated LED bulb.



a. Failure of one or more of the sensing/logic contacts. A qualified service technician is required to trouble shoot this specific condition. Switch the utility control circuit isolation switch to the de-energized position to remove utility control power. To isolate the AC voltage sensing and control circuits, remove the isolation plugs PL12 and PL15.

**NOTE:** The AC power conductors will still remain energized. Once all the control and voltage sensing circuits are de-energized and isolated the Service Disconnected pilot light will not illuminate due to loss of control power.

**NOTE:** To return the transfer switch back to normal operation, the utility control circuit disconnect switch and ATS Power Chassis & Voltage Sensing Isolation Plugs (PL12 & PL 15) must be switched on and reconnected for correct operation.

3. If the position of the transfer switch mechanism is not in the Neutral position, manually operate the transfer switch mechanism as follows:

**NOTE:** Refer to product drawings in sections 12, 13 & 14 for identification of Transfer Switch Mechanism style supplied with the Transfer Switch.

- **S-Style Mechanism:** Insert the operating handle into the front of the transfer mechanism and turn the operating handle until the position indication on the mechanism clearly shows the Neutral position.

**WARNING**

**Failure to move the mechanism to the Neutral Position may result in serious personal injury or death due to electrical shock.**

4. Close the transfer switch door securely using a suitable tool. Lock the door in the closed position and remove the key.

**WARNING**

**Failure to positively lock closed and secure the transfer switch door may result in serious personal injury or death due to electrical shock.**

5. Attach a safety lockout padlock to the service disconnect control switch to prevent unauthorized change in operating condition and verify transfer switch door is locked closed.





6. To re-energize the load, remove the padlock(s) from the service disconnect control switch, and move the switch to the Energized position. The transfer switch will immediately return to the utility or generator supply if within normal operating limits.

#### 5.4.5. ADDITIONAL SERVICE DISCONNECT PROCEDURES (MO STYLE ATS MECHANISM)

If the Service Disconnected pilot light is not illuminated, the service will not have been successfully disconnected and therefore it is not safe to perform any maintenance until the following additional procedures are performed:

##### **DANGER**

**Arc Flash and Shock Hazard. Will cause severe injury or death. Do not open equipment until ALL power sources are disconnected.**

**This equipment must be installed and serviced only by qualified electrical personnel utilizing safe work practices and appropriate Personal Protective Equipment (PPE). Failure to do so may cause personal injury or death.**

1. Visually inspect the actual position of the transfer switch power switching devices. If both power switching devices indicate they are open, the transfer switch is clearly in the Neutral position, the service has been successfully disconnected. Proceed to Step. 4.

If either power switching device is not in the Open position, or the load bus is energized, further procedures are required.

**NOTE:** If the power switching devices are both Open, the Service Disconnected pilot light may not have illuminated due to the following reasons:

- a) Utility and generator supply voltages are not present (the TSC 900 requires AC supply voltage to be present to power the pilot light).
- b) The pilot light may be burnt out. The bulb should be immediately replaced with a 6Vdc rated LED bulb.
- b. Failure of one or more of the sensing/logic contacts. A qualified service technician is required to trouble shoot this specific condition. Switch the utility control circuit isolation switch to the de-energized position to remove utility control power. To isolate the ATS Power Chassis & Voltage Sensing circuits, remove the isolation plugs PL12 and PL15.

**NOTE:** The AC power conductors will still remain energized. Once all the control and voltage sensing circuits are de-energized and isolated the







Service Disconnected pilot light will not illuminate due to loss of control power.

**NOTE:** To return the transfer switch back to normal operation, the utility control circuit disconnect switch and ATS Power Chassis & Voltage Sensing Isolation Plugs (PL12 & PL 15) must be switched on and reconnected for correct operation.

2. If the position of both power switching units are not in the Open position, the power switching units must be manually operated as follows. To operate manually, push the power switching units Open pushbutton. The unit should then open. Repeat for the other power switching unit.
3. Close all transfer switch doors securely using a suitable tool. Lock the door in the closed position and remove the key.

**WARNING**

**Failure to move the mechanism to the Neutral Position may result in serious personal injury or death due to electrical shock.**

4. Attach a safety lockout padlock to the service disconnect control switch to prevent unauthorized change in operating condition and verify transfer switch door is locked closed.
5. To reenergize the load, remove the padlock(s) from the service disconnect control switch, and move the switch to the Energized position. The transfer switch will immediately return to the utility or generator supply if within normal operating limits.

### 5.5. TEST MODES

The transfer switch may be tested utilizing the TSC 900 GHC display push-buttons, optional four position test switch (If fitted) or remote power fail test switch. A simulated utility power failure condition will be activated when the test mode is selected. The transfer switch will operate as per a normal utility power fail condition.

The transfer switch will remain on generator supply until the test mode is terminated. It will then immediately transfer back to the utility supply and then continue to operate the generator set for its cooldown period then stop.

**NOTE:** The transfer switch will automatically return to the utility supply (if within nominal limits) if the generator set fails while in the test mode.







## 6. OVER CURRENT PROTECTION

Thomson Power Systems **TS 870** series of Automatic Transfer Switches may be supplied with or without integral over current protection as described below:

### 6.1. STANDARD TS 870 AUTOMATIC TRANSFER SWITCH

The standard TS 870 Automatic Transfer Switch does not contain any integral over current protection and requires upstream over current protection devices for both Utility and Generator sources. The Standard TS 870 can withstand a maximum short circuit fault current as noted in [SECTION 16](#) of this manual. The standard TS 870 transfer switch model without integral over current protection is identified in the product model code. Refer to [SECTION 4.3](#) of this manual for further details on model coding.

### 6.2. OPTIONAL TS 870 AUTOMATIC TRANSFER SWITCH WITH INTEGRAL OVER CURRENT PROTECTION

TS 870 transfer switches will have integral over current protection supplied on the Utility source as standard. The type of over current protection utilized is dependent upon ATS amperage size and optional features specified. For transfer switches rated 100A through 200A, over current protection is non-adjustable thermal-magnetic type trip units. For transfer switches rated 250A through 1200A over current protection is adjustable electronic type with long time & instantaneous trip unit elements with optional ground fault protection elements.

**NOTE:** Ground fault protection is supplied as standard on 1000A and 1200A transfer switches that are used on systems greater than 240V.

An upstream over current protection device is required on the generator source which feeds the TS 870 Transfer Switch if integral over current protection option is not specified on the ATS.

**NOTE:** For models of transfer switch with adjustable integral over current protection trip units, the over current protection must be set prior to operation. The equipment will be shipped from the factory with a long-time current setting of 100% (of the equipment rating) and maximum instantaneous/short-time current and time delay settings.

#### WARNING

**Do Not Energize this equipment until device settings have been verified to ensure proper system protection & coordination. Failure to do so may result in equipment failure.**

Refer to [SECTION 4.3](#) Product Model Code for types of integral over current protection which are supplied with the transfer switch.





## 7. GENERAL NOTES ON SERVICING TRANSFER SWITCH MECHANISMS

### DANGER

**Arc Flash and Shock Hazard. Will cause severe injury or death. Do not open equipment until ALL power sources are disconnected. This equipment must be installed and serviced only by qualified electrical personnel utilizing safe work practices and appropriate Personal Protective Equipment (PPE). Failure to do so may cause personal injury or death.**

**NOTE:** Refer to section 4.2 of this manual for identification of Transfer Switch Mechanism styles supplied for the Transfer Switch.

When performing any service work on the transfer mechanism, it is imperative that the following be observed:

**7.1.** To maintain mechanical integrity, ensure that:

- On T Style mechanisms, all limit switches are correctly adjusted to provide full travel of the power switching device toggles without exerting unnecessary forces associated with excessive travel. Ensure that power switching device travel far enough to reset any internal trip unit (it is more important for the toggle to go fully in the Off direction, than in the On direction).
- Mechanical interlocking is correct when one power switching opens well before the other should close.
- All fasteners are adequately tightened.
- The operating linkages are not damaged or bent, and that all bearing points operate freely.
- On S Style transfer switch mechanisms, check nylock nuts on bolt pivot points. Operation arms should move freely without excessive play.

**7.2.** To maintain electrical integrity, ensure that:

- All electrical connections, especially power connections, are clean and adequately tightened. Corroded or loose power connections will cause destructive heating, and may cause premature tripping.
- All insulating devices are in place and in good condition.
- No moisture or other contamination is present.
- Electrical conductors are adequately secured away from moving parts.



**7.3.** To maintain operational integrity, ensure that:

- All control devices are in good condition and correctly calibrated.
- All control devices including TSC 900 connectors are adequately secured in their plug-in fixtures.

Only qualified personnel should undertake Service work. Failure to correctly maintain an automatic transfer switch may present a hazard to life and equipment. Full operational testing must be done prior to placing a transfer switch in service subsequent to any maintenance or repair. Any service work involving electrical components requires high-potential testing to ensure that required insulation levels have been maintained.



## 8. ATS MANUAL OPERATING INSTRUCTIONS

### DANGER

Arc Flash and Shock Hazard. Will cause severe injury or death. Do not open equipment until ALL power sources are disconnected. This equipment must be operated only by qualified electrical personnel utilizing safe work practices and appropriate Personal Protective Equipment (PPE). Failure to do so may cause personal injury or death.

### 8.1. S-STYLE ATS -MANUAL OPERATION

The transfer switch maybe operated manually for maintenance or emergency operation conditions provided both Utility and Generator supplies are de-energized prior to manual operation.



### DANGER

#### HAZARD OF ELECTRICAL SHOCK, EXPLOSION, OR ARC FLASH

This equipment must be serviced only by qualified electrical personnel utilizing safe work practices and appropriate Personal Protective Equipment (PPE).

Many components of this equipment operate at line voltage.

**DO NOT TOUCH.** Use only electrically isolated tools.

Install and close all covers before applying power to this equipment

Do not open covers to equipment until ALL power sources are disconnected

Failure to do so may cause personal injury or death

Once both Utility and Generator supplies are de-energized the following procedure can be used to operate the Transfer Switch manually.

1. Disconnect the ATS Power Chassis & Voltage Sensing Isolation Plugs (PL12 & PL15) to prevent automatic operation.
2. Open ATS enclosure door and locate Manual Operation Handle provided with the transfer switch (see photo below)

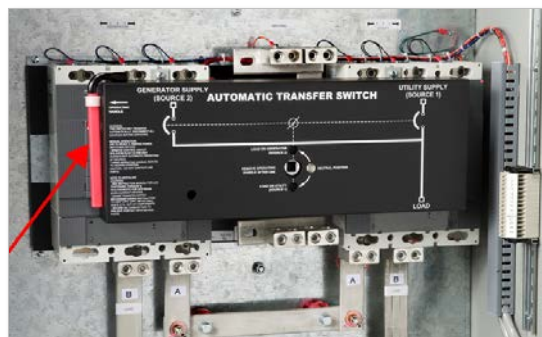

Manual Operation Handle



3. Insert manual handle into the center hole of the transfer switch mechanism.
4. To manually operate mechanism, rotate handle to the desired position as labeled on the ATS mechanism cover. Do not over-torque handle once position has been attained.
5. Once ATS is manually operated to desired position, re-close ATS enclosure door, then re-energize supply sources to re-energize the load.



## 8.2. T-STYLE ATS -MANUAL OPERATION

The transfer switch maybe operated manually for maintenance or emergency operation conditions provided both Utility and Generator supplies are de-energized prior to manual operation.



### DANGER

#### HAZARD OF ELECTRICAL SHOCK, EXPLOSION, OR ARC FLASH

This equipment must be serviced only by qualified electrical personnel utilizing safe work practices and appropriate Personal Protective Equipment (PPE).

Many components of this equipment operate at line voltage.

**DO NOT TOUCH.** Use only electrically isolated tools.

Install and close all covers before applying power to this equipment

**Do not open covers to equipment until ALL power sources are disconnected**

**Failure to do so may cause personal injury or death**

Once both Utility and Generator supplies are de-energized the following procedure can be used to operate the Transfer Switch manually.

1. Disconnect the ATS Power Chassis & Voltage Sensing Isolation Plugs (PL12 & PL15) to prevent automatic operation.
2. Open ATS enclosure door and locate Manual Operation Handle knob (see photo below).



Manual Operation Handle Knob



3. Pull the manual handle towards yourself to dis-engage the manual handle rod from the motor drive mechanism.
4. To manually operate mechanism, push Manual Operation Handle knob handle up or down to the desired position as labeled on the ATS Toggle arms.
5. Once ATS is manually operated to desired position, re-close ATS enclosure door, then re-energize supply sources to re-energize the load.





### 8.3. MO STYLE ATS -MANUAL OPERATION

The MO-Style Transfer Switch can be operated manually using either electrically operated push buttons located on the front of the ATS door, or using the mechanical operated pushbuttons inside the ATS on the front of each power switching device.

**NOTE:** It is not recommended to use the internally mounted pushbuttons unless in an emergency condition should the electrical operated buttons fail to operate the ATS manually.

#### 8.3.1. ELECTRICALLY OPERATED ATS DOOR PUSH BUTTONS

Manual Operation of the ATS is selected either by a door mounted 2 position control switch or via internal software selection on the TSC 900 Controller.

**AUTO:** This selects automatic operation of the transfer switch. The power switching device will automatically open/close as detailed in the sequence of operation per section 5 of this manual.

**MAN:** This position inhibits automatic operation and automatic engine starting. The power switching device can be manually operated via electrically interlocked push buttons located on the front of the ATS door and position pilot lights.

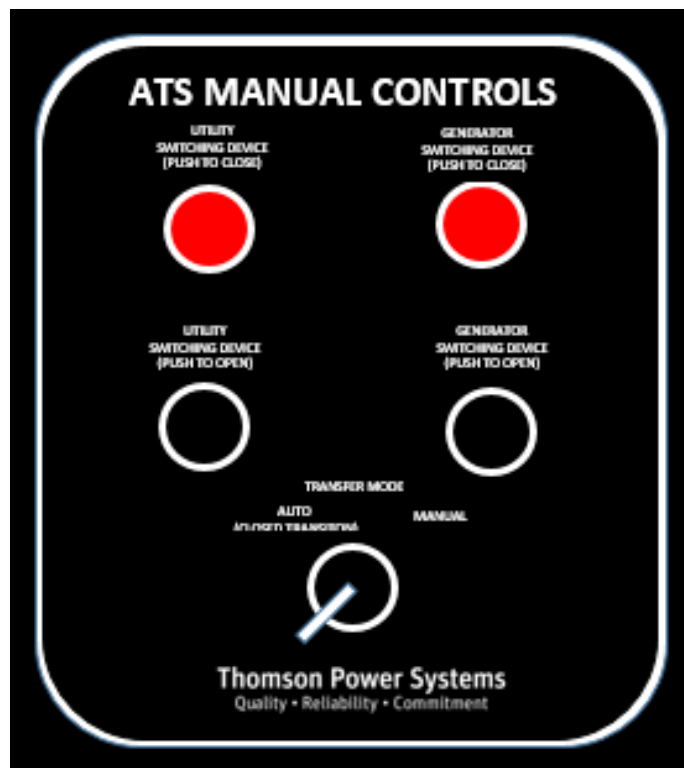

**NOTE**

**When the Manual Mode is selected the engine start output logic is disabled. Where generator voltage is required during manual operation the local generator controls must be set for manual operation.**

**MANUAL TRANSFER TO GEN SUPPLY (Open Transition)**

To transfer manually to generator supply, follow procedure listed below;

1. Turn the Transfer Switch door mounted Mode selector to Manual or Select Man mode on TSC 900 Controller (refer to TSC 900 manual for further information).
2. Manually start the generator set at its local control panel, and ensure it is operating at normal voltage and frequency, with its output circuit breaker closed.
3. Manually open the utility power switching device using the Open pushbutton located on the ATS door. Verify the utility power switching device contacts are open via Green (O) Open contact status flag.
4. Ensure the generator power switching device's spring mechanism is fully charged as indicated by Yellow –Spring Charged flag. If the power switching device is not charged, it may be manually charged by locating the manual charge handle mechanism on the face of the power switching device, then pulling forward and then down 1-6 times until the Yellow Spring Charged flag is displayed. Refer to Diagrams #1 & 2 below and the power switching device's manual for further information.

**NOTE:**

**The yellow OK Flag indicates the power switching device is charged however it may not be ready to close if the transfer switch mechanical or electrical interlocks are not satisfied.**

5. If the generator supply is at normal voltage and frequency levels, manually Close the generator power switching device using the Red (I) Mechanical Close pushbutton located on the face of the power



switching device. Refer to Diagrams #1 & #2 below. Verify the generator power switching device contacts are closed via Red (I) Closed contact status flag.

**NOTE:**

**If the Transfer Switch is supplied with Closed Transition Transfer feature, the mechanical close push button on the face of the power switching unit is not available for use. A separate electrical close push button located on the power switching unit door is provided for manual closing. Power switching unit closure is only permitted in open transition mode (i.e. Utility power switching device must be open)**





## MANUAL TRANSFER TO UTILITY SUPPLY (Open Transition)

To transfer manually to the utility supply, follow procedure listed below;

1. Turn the Transfer Switch door mounted System Operation Mode selector to MANUAL or Select MAN mode on TSC 900 Controller (refer to TSC 900 manual for further information).
2. Manually open the generator power switching device using the red (O) Mechanical Open pushbutton located on the face of the power switching device. Refer to Diagram #1. Verify the generator power switching device contacts are open via Green (O) open contact status flag.
3. Ensure the utility power switching device's spring mechanism is fully charged as indicated by yellow –Charged OK flag. If the power switching device is not charged, it maybe manually charged by locating the manual charge handle mechanism on the face of the power switching device, then pulling forward and then down 1-4 times until the yellow Charged OK flag is displayed. Refer to diagram #1 and the power switching device's manual for further information.

### NOTE

**The yellow OK Flag indicates the power switching device is charged however it may not be ready to close if the transfer switch mechanical or electrical interlocks are not satisfied**

4. If the utility supply is at normal voltage and frequency levels, manually Close the utility power switching device using the black (I) Mechanical Close pushbutton located on the face of the power switching device. Refer to Diagram #1. Verify the utility power switching device contacts are closed via red (I) closed contact status flag.

### NOTE:

**If the Transfer Switch is supplied with Closed Transition Transfer feature, the mechanical close push button on the face of the power switching unit is not available for use. A separate electrical close push button located on the power switching unit door is provided for manual closing. Power switching unit closure is only permitted in open transition mode (i.e. Gen power switching device must be open)**





5. The generator set should be manually turned off at the local control panel.

### 8.3.2. MECHANICALLY OPERATED POWER SWITCHING DEVICE PUSH BUTTONS

#### MANUAL TRANSFER TO GENERATOR SUPPLY (Open Transition)

To transfer manually to generator supply, follow procedure listed below;

1. Turn the Transfer Switch door mounted System Operation Mode selector to manual or Select MAN mode on TSC 900 Controller (refer to TSC 900 manual for further information).
2. Manually start the generator set at its local control panel, and ensure it is operating at normal voltage and frequency, with its output circuit breaker closed.
3. Manually open the utility power switching device using the red (O) Mechanical Open pushbutton located on the face of the power switching device. Refer to Diagrams #1 & 2 below. Verify the utility power switching device contacts are open via Green (O) open contact status flag.
4. Ensure the generator power switching device's spring mechanism is fully charged as indicated by yellow –Spring Charged flag. If the power switching device is not charged, it maybe manually charged by locating the manual charge handle mechanism on the face of the power switching device, then pulling forward and then down 1-6 times until the yellow Spring Charged flag is displayed. Refer to Diagrams #1 & 2 below and the power switching device's manual for further information.

#### NOTE

**The yellow OK Flag indicates the power switching device is charged however it may not be ready to close if the transfer switch mechanical or electrical interlocks are not satisfied.**

5. If the generator supply is at normal voltage and frequency levels, manually Close the generator power switching device using the red (I) Mechanical Close pushbutton located on the face of the power switching device. Refer to Diagrams #1 & #2 below. Verify the generator power switching device contacts are closed via red (I) closed contact status flag.



**NOTE**

If the Transfer Switch is supplied with Closed Transition Transfer feature, the mechanical close push button on the face of the power switching unit is not available for use. A separate electrical close push button located on the power switching unit door is provided for manual closing. Power switching unit closure is only permitted in open transition mode (i.e. Utility power switching device must be open)

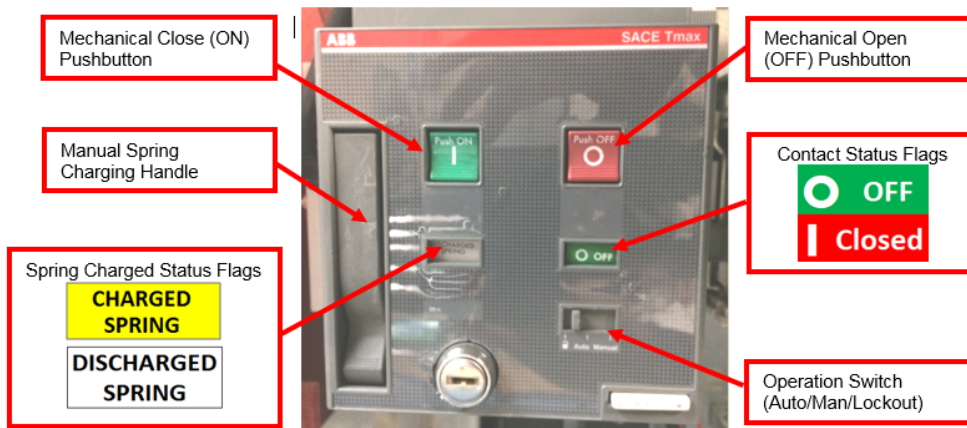

**DIAGRAM #1**

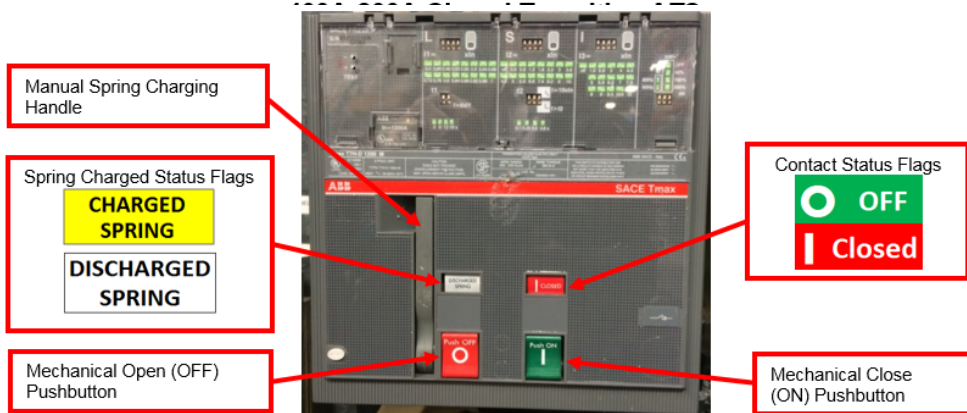

**DIAGRAM #2**  
**1000A-1200A Open/Closed Transition ATS**  
**Power Switching Device**



## MANUAL TRANSFER TO UTILITY SUPPLY (Open Transition)

To transfer manually to the utility supply, follow procedure listed below;

1. Turn the Transfer Switch door mounted System Operation Mode selector to MANUAL or Select MAN mode on TSC 900 Controller (refer to TSC 900 manual for further information).
2. Manually open the generator power switching device using the red (O) Mechanical Open pushbutton located on the face of the power switching device. Refer to Diagram #1. Verify the generator power switching device contacts are open via green (O) open contact status flag.
3. Ensure the utility power switching device's spring mechanism is fully charged as indicated by yellow –Charged OK flag. If the power switching device is not charged, it maybe manually charged by locating the manual charge handle mechanism on the face of the power switching device, then pulling forward and then down 1-4 times until the yellow Charged OK flag is displayed. Refer to diagram #1 and the power switching device's manual for further information.

### NOTE

**The yellow OK Flag indicates the power switching device is charged however it may not be ready to close if the transfer switch mechanical or electrical interlocks are not satisfied.**

4. If the utility supply is at normal voltage and frequency levels, manually Close the utility power switching device using the black (I) Mechanical Close pushbutton located on the face of the power switching device. Refer to Diagram #1. Verify the utility power switching device contacts are closed via red (I) closed contact status flag.

### NOTE

**If the Transfer Switch is supplied with Closed Transition Transfer feature, the mechanical close push button on the face of the power switching unit is not available for use. A separate electrical close push button located on the power switching unit door is provided for manual closing. Power switching unit closure is only permitted in open transition mode (i.e. Gen power switching device must be open)**

5. The generator set should be manually turned off at the local control panel.





**RECOMMENDED MAINTENANCE****DANGER**

**Arc Flash and Shock Hazard. Will cause severe injury or death.**

**Do not open equipment until ALL power sources are disconnected**

**This equipment must be installed and serviced only by qualified electrical personnel utilizing safe work practices and appropriate Personal Protective Equipment (PPE).**

**Failure to do so may cause personal injury or death**

- 10.1.** DO NOT perform dielectric tests on the equipment with the control components in the circuit.
- 10.2.** Check if control components are tight in sockets.
- 10.3.** Periodically inspect all terminals (load, line and control) for tightness. Re-torque all bolts, nuts and other hardware. Clean or replace any contact surfaces, which are dirty, corroded or pitted.
- 10.4.** Transfer switches should be in a clean, dry and moderately warm location. If signs of moisture are present, dry and clean transfer switch. If there is corrosion, try to clean it off. If cleaning is unsuitable, replace the corroded parts. Should dust and/or debris gather on the transfer switch, brush, vacuum, or wipe clean. DO NOT blow dirt into power switching devices.
- 10.5.** Test the transfer switch operation. While the unit is exercising, check for freedom of movement, hidden dirt, corrosion or any excessive wear on the mechanical operating parts. Ensure that the power switching device travel is correct.
- 10.6.** Verify all program settings on the TSC 900 controller as per the TSC 900 component calibration label on the rear cover of the controller.
- 10.7.** Transfer Mechanism 1000A-1200A-T Style ensure that the manual handle moves freely on the hub when the lock pin is disengaged. If lubrication is necessary, apply medium weight (SAE 20) oil sparingly.
- 10.8.** Transfer Mechanism 1000A-1200A T Style - yoke pivot bearings and rod ends are permanently lubricated and do not require maintenance.
- 10.9.** Transfer Mechanism 100A-800A S Style - lubrication of drive hub/operator arm interface. Use high viscosity moly lubricant.
- 10.10.** The motor and gearbox on all Transfer Mechanism styles are permanently lubricated, and should not require attention under normal operating circumstances.



## 9. FRONT VIEW (TYPICAL) 3 / 4 POLE 100A-250A S-Style TRANSFER MECHANISM

NOTE 1: 3 PHASE CONNECTION SHOWN. FOR SINGLE PHASE CONNECT TO A & B ONLY

NOTE 2: CONTROL CIRCUIT ISOLATION PLUG IS LOCATED ON INSIDE OF ENCLOSURE DOOR.

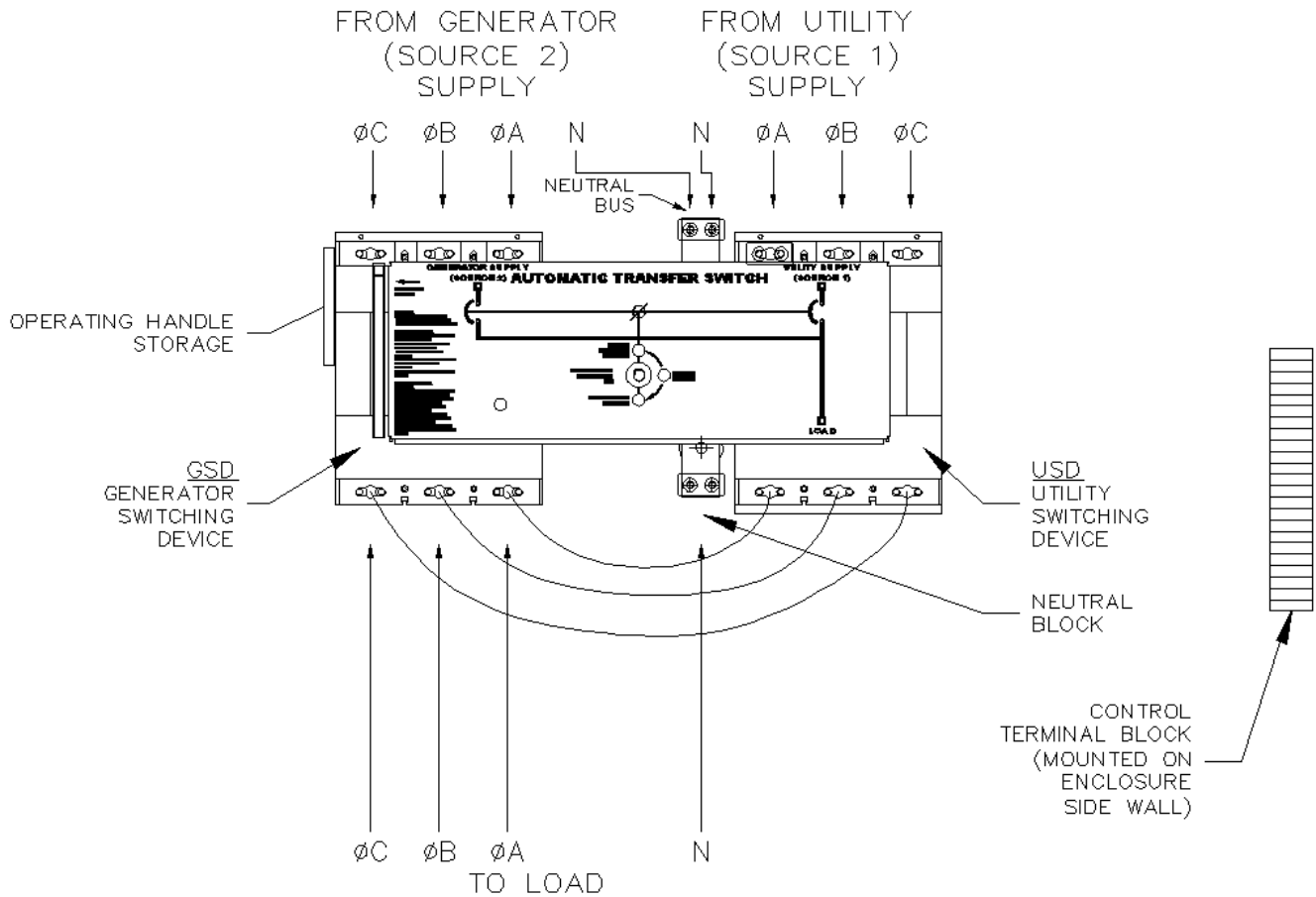

# 10. FRONT VIEW (TYPICAL) 3 POLE 400A-800A S-Style TRANSFER MECHANISM (Mechanism Front Cover Removed)

NOTE 1: 3 PHASE CONNECTION SHOWN. FOR SINGLE PHASE CONNECT TO A & C ONLY

NOTE 2: CONTROL CIRCUIT ISOLATION PLUG IS LOCATED ON INSIDE OF ENCLOSURE DOOR.

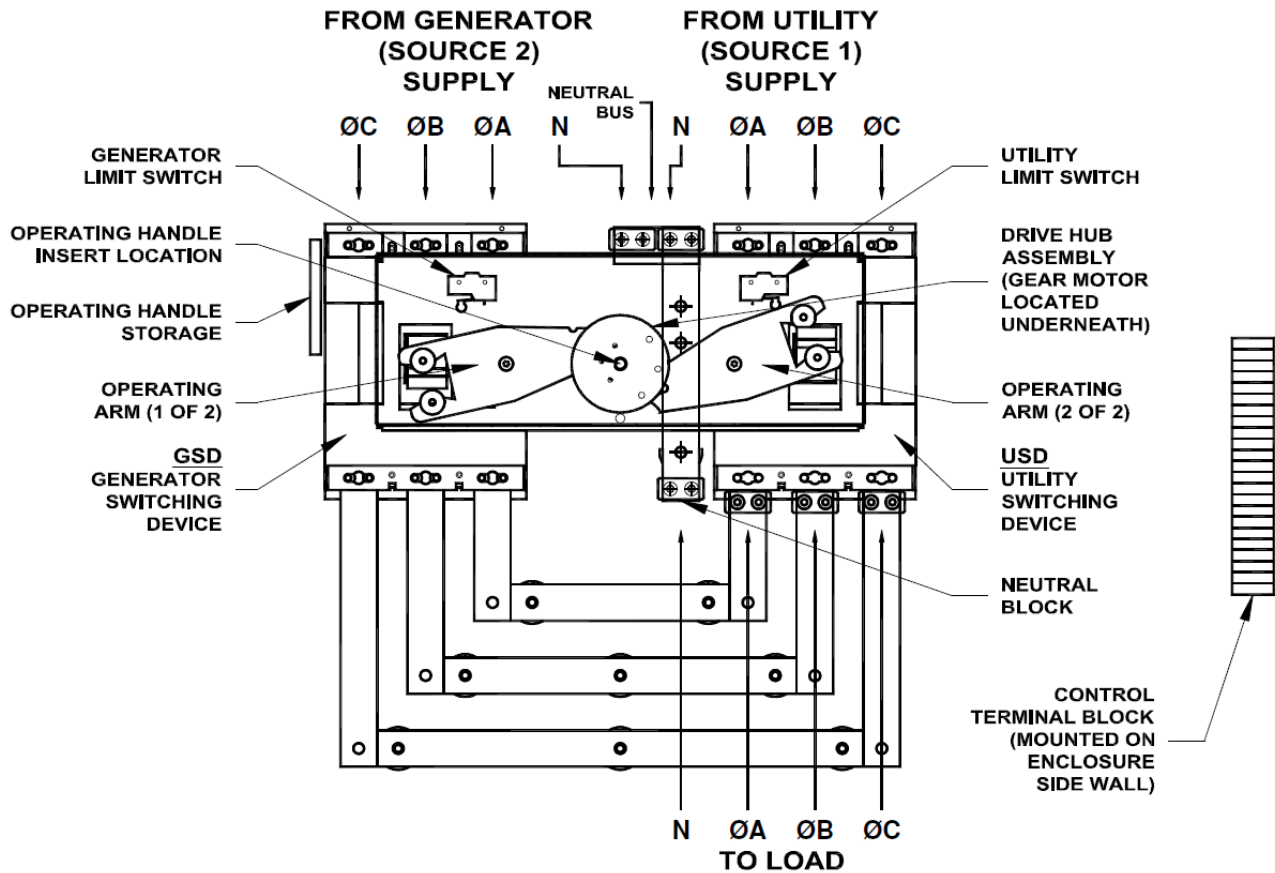



**11. FRONT VIEW (TYPICAL) 3 / 4 POLE MOTOR OPERATOR (MO) STYLE TRANSFER MECHANISM (400A-800A CLOSED TRANSITION, 1000-1200A)**

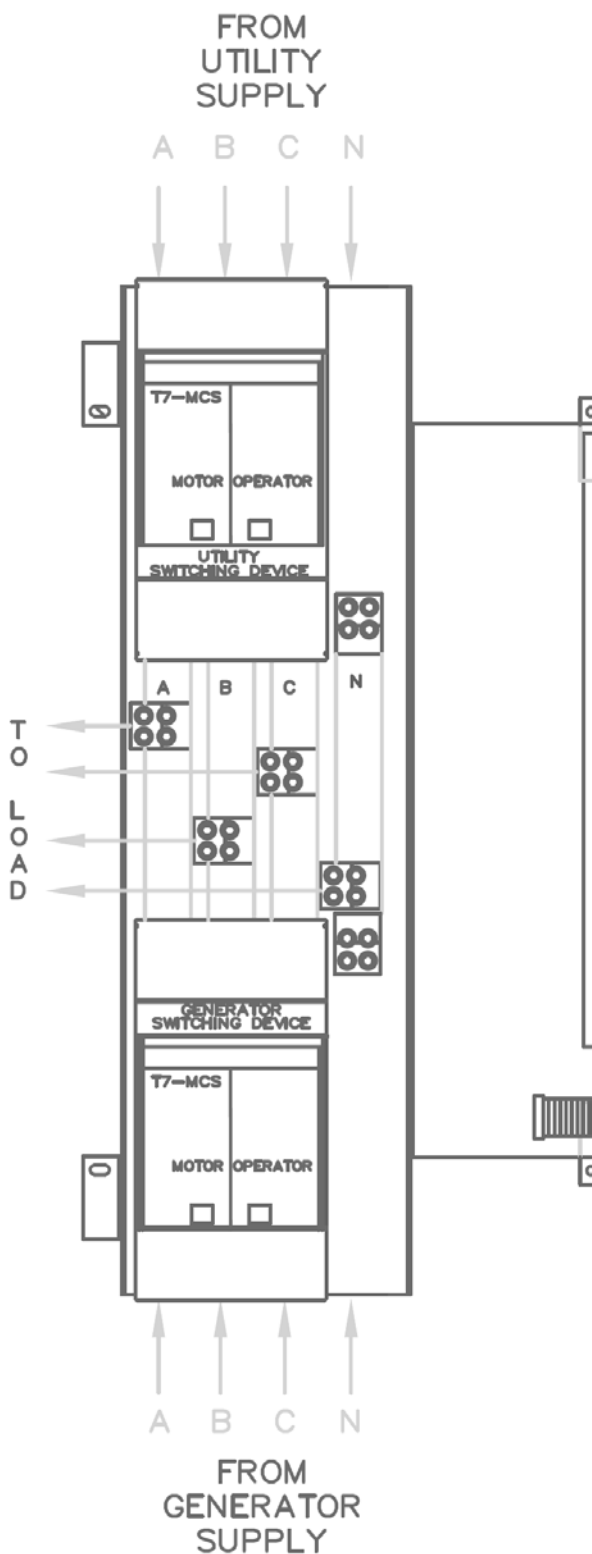

## 12. CABLE TERMINAL INFORMATION

BASIC MODEL	TERMINAL RATING		CONNECTION TIGHTNESS (In-lbs.)	
	QTY PER PHASE	RANGE	TERMINAL MOUNTING SCREW	CABLE CLAMP
TS 87xA-0100	1	#14-1/0	120	50
TS 87xA-0150	1	#2-4/0	120	120
TS 87xA-0200	1	#6-350MCM	150	275
TS 87xA-0250	1	#6-350MCM	150	275
TS 87xA-0400 <sup>1</sup>	2	2/0- 500MCM	72	275
TS 87xA-0600 <sup>1</sup>	2	2/0- 500MCM	72	275
TS 87xA-0800 <sup>1</sup>	3	2/0- 500MCM	110	375
TS 87xA-1200 <sup>1</sup>	4	4/0- 500MCM	375	375

1. Optional terminal ratings are available in some models – Consult Thomson Power Systems.
2. For other model types not shown, contact Thomson Power Systems for further information.

## 13. REQUIREMENTS FOR UPSTREAM CIRCUIT PROTECTIVE DEVICES

### 13.1. WITHSTAND CURRENT RATINGS (ALL MODELS WITHOUT INTEGRAL OVERCURRENT PROTECTION OPTION)

BASIC MODEL	MAX. VOLTAGE	RATED CURRENT (A)	WITHSTAND CURRENT RATING AMPS (RMS) <sup>1</sup>		
			@240V	@480V	@600V
TS87xA-0100	600	100	65,000	25,000	18,000
TS87xA-0150	600	150	65,000	25,000	18,000
TS87xA-0200	240	200	65,000	N/A	N/A
TS87xA-0250	600	250	65,000	35,000	25,000
TS87xA-0400	600	400	65,000	50,000	35,000
TS87xA-0600	600	600	65,000	50,000	35,000
TS87xA-0800	600	800	65,000	50,000	35,000
TS87A-1000/1200	600	1000/1200	65,000	50,000	42,000

1. Standard ratings only are shown. Consult Thomson Power Systems for versions with higher withstand current ratings.
2. For other model types not shown, contact Thomson Power Systems for further information.



### 13.2. INTERRUPTING CAPACITY CURRENT RATINGS (ALL MODELS WITH INTEGRAL OVERCURRENT PROTECTION OPTION)

BASIC MODEL	MAX. VOLTAGE	RATED CURRENT (A)	INTERRUPTING CAPACITY CURRENT RATING AMPS (RMS) 1		
			No Upstream Overcurrent Protection Required		
			@240V	@480V	@600V
TS87xA-0100	600	100	65,000	25,000	14,000
TS87xA-0150	600	150	65,000	25,000	14,000
TS87xA-0200	240	200	65,000	N/A	N/A
TS87xA-0250	600	250	65,000	35,000	22,000
TS87xA-0400	600	400	65,000	50,000	25,000
TS87xA-0600	600	600	65,000	50,000	25,000
TS87xA-0800	600	800	65,000	50,000	25,000
TS87xA-1000/1200	600	1000/1200	65,000	50,000	50,000

1. Standard ratings only are shown. Consult Thomson Power Systems for versions with higher interrupting capacity current ratings.
2. For other model types not shown, contact Thomson Power Systems for further information.

## 14. GROUND FAULT SITE TEST REQUIREMENTS

Per NEC and UL1008, a ground fault protected system shall be performance tested when first installed on site. A written record of this shall be made and be available to the authority having jurisdiction. A form is provided at the back of this manual for this purpose – see **SECTION 22**.

Confirm and record actual trip set points in the form provided which is to be made available on request by inspection authority.

### 14.1. PERFORMANCE TEST

Qualified Field Service technicians require a calibrated current injection test apparatus and must be knowledgeable in breaker testing to provide primary neutral CT injection up to or greater than the trip set point as selected by the responsible party. As indicated in the NEC,





the maximum setting of the ground fault protection shall be 1200 amps, and the maximum time delay shall be 1 second for ground faults equal to or greater than 3000 amps.

The inspection authority should be contacted to confirm actual test requirements as these may vary by region or local code requirements.

The interconnected system shall be evaluated to ensure compliance with the appropriate schematic drawings. The proper location of sensors and power cabling shall be determined. The grounding points of the system shall be verified to determine that ground paths do not exist that would bypass the sensors. The use of high-voltage testers and resistance bridges may be required. A simulated fault current is to be generated by a coil around the sensors. The reaction of the circuit-interrupting device is to be observed for correct response. The results of the test are to be recorded on the test form provided.

## 15. TROUBLESHOOTING

### **DANGER**

**Arc Flash and Shock Hazard. Will cause severe injury or death.**

**Do not open equipment until ALL power sources are disconnected**

**This equipment must be installed and serviced only by qualified electrical personnel utilizing safe work practices and appropriate Personal Protective Equipment (PPE). Failure to do so may cause personal injury or death**





MALFUNCTIONS	PROBABLE CAUSES	CORRECTIVE ACTIONS
<b>Will not re-transfer to utility source upon restoration</b>	Utility Return Time delay period in TSC 900 has not yet expired.	Verify TSC 900 time delay setting
	A Load Test mode has been activated locally or remotely	Check TSC 900 GHC Home Page status indicators
	An Exercise Test mode has been activated by the TSC 900 scheduler	Check TSC 900 GHC Scheduler page
	Utility supply is not operating at correct voltage or frequency levels.	Verify correct nominal levels the utility source should be operating at and compare to TSC 900 settings for under/over voltage, voltage phase balance and under/over frequency
	TSC 900 has incorrect utility voltage or frequency settings for the ATS.	Re-Program TSC 900 with correct settings as required for voltage or frequency.
	Utility Phase Rotation is not matched with Generator supply (first time transfer).	Check Generator & Utility Voltage Phase rotation matches on TSC 900 GHC Utility & Generator Voltage Pages. If power cabling has non-matching phase rotation, reverse power conductors on one phase on one of the supplies
	TSC 900 connection plugs are unplugged (J1,2,3,4)	Verify all TSC 900 connectors are fully inserted
	ATS Power Chassis & Voltage Sensing Isolation Plugs (PL12 or PL15) are unplugged	Verify both PL12 & PL15 connectors are fully inserted
	TSC 900 has "Transfer Fail" alarm activated.	Determine cause of alarm and rectify before TSC 900 is reset on GHC
	Defective Utility power switching unit close coil (MO Style ATS Mechanism only)	Verify Utility power switching device close coil is fully functional.
	Defective generator power switching unit trip coil (open transition) (MO Style ATS Mechanism only)	Verify Gen power switching device trip coil is fully functional. The generator power switching unit must be open before the utility power switching device is permitted to close (open transition).
	Defective ATS mechanism motor (S or T-Style ATS Mechanism only)	Verify motor does not rotate when 120VAC is applied directly to motor leads. If defective Return to Thomson Power systems using RMA process
A loose control wire connection	Check all wiring connections in the ATS	







<p><b>Will not re-transfer to utility source upon restoration (cont'd)</b></p>	<p>Defective TSC 900 controller</p>	<ul style="list-style-type: none"> <li>Verify TSC 900 has 120VAC control power applied to the utility control power input (J1- 15, 16) and Diagnostic green LED is flashing.</li> <li>Verify TSC 900 has 120VAC control power applied to the ATS Utility closed control contact (J1-9)</li> <li>Verify TSC 900 SCU has SD Memory Card fully inserted into socket.</li> </ul> <p>If defective, return to Thomson Power systems using RMA process</p>
	<p>Faulty motor limit switch (S or T-Style ATS Mechanism only)</p>	<p>Verify Utility side limit switch (ULS) n/c contact is closed and is low resistance when ATS mechanism is <u>not</u> in the utility position.</p>
	<p>Faulty Generator power switching device auxiliary switch (MO Style ATS Mechanism only)</p>	<p>Verify Generator side auxiliary switch (G-AUX) n/c contact is closed and is low resistance when Generator switching device is open. Verify TSC 900 Digital input for Gen Power Switching Device is Open has been activated</p>
	<p>A Transfer Inhibit signal has been activated</p>	<p>Check TSC 900 indicators if a utility transfer inhibit signal has been activated and reset)</p>
	<p>On Service Entrance Rated ATS, Service Disconnect switch is in the “De-Energized” or “Transfer to Neutral” positions.</p>	<p>Switch to the Energized position</p>
	<p>On Service Entrance Rated ATS, Utility Voltage Disconnect switch inside ATS is switched to “Off” position.</p>	<p>Switch Utility Voltage Disconnect switch to the “On” position</p>
<p><b>Will not transfer to generator source upon failure of utility source</b></p>	<p>Warm-up time delay function has not timed out yet</p>	<p>Verify TSC 900 timer setting</p>
	<p>Generator set output circuit breaker which feeds ATS is open</p>	<p>Close generator set output circuit breaker</p>
	<p>Generator supply is not operating at correct voltage or frequency levels.</p>	<p>Verify correct nominal levels the generator should be operating at and compare to TSC 900 Settings for under/over voltage, voltage phase balance and under/over frequency</p>
	<p>TSC 900 has incorrect generator voltage or frequency settings for the ATS.</p>	<p>Re-Program TSC 900 with correct settings as required for voltage or frequency.</p>
	<p>Generator Phase Rotation may not match Utility supply (First Time Transfer).</p>	<p>Check Generator &amp; Utility Voltage Phase rotation matches on TSC 900 GHC Utility &amp; Generator Voltage Pages. If power cabling has non-matching phase rotation, reverse power conductors on one phase on one of the supplies</p>
	<p>TSC 900 connection plugs are unplugged (J1,2,3,4)</p>	<p>Verify all TSC 900 connectors are fully inserted</p>





<p><b>Will not transfer to generator source upon failure of utility source (con't)</b></p>	<p>ATS Power Chassis &amp; Voltage Sensing Isolation Plugs (PL12 or PL15) are unplugged</p>	<p>Verify both PL12 &amp; PL15 connectors are fully inserted</p>
	<p>TSC 900 has "Transfer Fail" alarm activated.</p>	<p>Determine cause of alarm and rectify before TSC 900 is reset on GHC</p>
	<p>Defective ATS mechanism motor</p>	<p>Verify motor does not rotate when 120VAC is applied directly to motor leads. If defective Return to Thomson Power systems using RMA process</p>
	<p>A loose control wire connection</p>	<p>Check all wiring connections in the ATS</p>
	<p>Defective TSC 900 controller</p>	<ul style="list-style-type: none"> <li>• Verify TSC 900 has 120VAC control power applied to the generator control power input (J1-12, 13) and Diagnostic green LED is flashing.</li> <li>• Verify TSC 900 has 120VAC control power applied to the ATS control contacts (J1-1).</li> <li>• Verify TSC 900 SCU has SD Memory Card fully inserted into socket.</li> </ul> <p>If defective Return to Thomson Power systems using RMA process</p>
<p>Faulty motor limit switch</p>	<p>Verify Generator side limit switch (GLS) n/c contact is closed and is low resistance when ATS mechanism is <u>not</u> in the generator position.</p>	
<p><b>Transfer to generator source without a power failure in the utility source</b></p>	<p>A Load Test mode has been activated locally or remotely</p>	<p>Check TSC 900 GHC Home Page status indicators</p>
	<p>An Exercise Test mode has been activated by the TSC 900 scheduler</p>	<p>Check TSC 900 GHC Scheduler page</p>
	<p>Utility supply is not operating at correct voltage or frequency levels.</p>	<p>Verify correct nominal levels the utility source should be operating at and compare to TSC 900 settings for under/over voltage, voltage phase balance and under/over frequency</p>
	<p>TSC 900 has incorrect utility voltage or frequency settings for the ATS.</p>	<p>Re-Program TSC 900 with correct settings as required for voltage or frequency.</p>
	<p>Utility power switching device has tripped open due to an over current condition and TSC 900 "Transfer Fail" alarm is activated on GHC.</p>	<p>Determine cause of alarm and rectify before TSC 900 is reset.</p>
	<p>A loose control wire connection</p>	<p>Check all wiring connections in the ATS</p>
<p>Defective TSC 900 controller</p>	<ul style="list-style-type: none"> <li>• Verify TSC 900 is reading correct Utility Voltage or frequency on GHC as compared to separate meter.</li> </ul> <p>If defective Return to Thomson Power Systems using RMA process</p>	





<b>Generator does not start or stop when it should</b>	Remote engine control panel is not set to automatic mode	Verify remote engine control panel is set for automatic operation
	Engine start contact is wired incorrectly from ATS to engine control panel	Verify engine start contact is wired correctly from ATS to engine control panel
	Incorrect TSC 900 Engine start contact is used	For single engine applications, use Engine Start Signal #2 contact on TSC 900 lower terminal block (J10b)
	TSC 900 Engine start contact terminal block (j10b) is unplugged	Verify 2 position TSC 900 terminal block j10b is fully inserted into controller and it is connected to correct position (i.e. lower TB)
	Defective TSC 900 SCU Engine Start relay/contact	<ul style="list-style-type: none"> <li>Verify Engine start signal LED diagnostic light is illuminated on SCU when engine is signaled to start. If LED is on, verify contacts are closing.</li> </ul> If defective Return TSC 900 SCU to Thomson Power Systems using RMA process
	Engine Start and/or Cooldown timers may be duplicated in both ATS control and Engine control Panel	Disable timers in either ATS or Engine control panel.
<b>No time delay when there should be</b>	Incorrect TSC 900 time delay setting	Verify TSC 900 timer setting
<b>Power is not available at the load terminals but the utility or generator power switching device appears to be closed to a live source</b>	Utility or Generator power switching device has tripped open due to an over current condition.	Power Switching device must be reset by <u>manually</u> operating the ATS mechanism to the other source, then back to the source which was tripped.
	Mechanism has failed to operate the power switching device toggle far enough to close the power switching unit.	Limit switch failure or improper adjustment. Contact Thomson Power system for adjustment procedure of limit switch
<b>The transfer switch has completed a transfer, but the motor has overheated and the internal thermal protector has opened</b>	Limit switch failure or improper adjustment	Contact Thomson Power system for adjustment procedure or replacement of limit switch
<b>GHC Display is not showing any system information</b>	GHC screen may be in a "sleep" mode.	Touch screen to re-activate LCD display
	GHC USB cable is unplugged at the GHC end or the SCU end	Verify USB cable is fully inserted into the GHC and SCU devices





<p><b>GHC Display is not showing any system information (con't)</b></p>	<p>Defective GHC Display</p>	<ul style="list-style-type: none"> <li>Temporarily unplug GHC USB cable for 5 seconds then re-inset to reboot GHC controller. Wait 30 seconds to determine if GHC reboots to normal operation.</li> <li>Verify TSC 900 GHC has SD Memory Card fully inserted into socket.</li> </ul> <p>If defective Return to Thomson Power Systems using RMA process</p>
	<p>TSC 900 SCU Control board is not powered from 120VAC Utility supply, 120VAC Generator supply, or 24Vdc aux supply (if fitted)</p>	<p>The GHC needs maintained 5Vdc power from the TSC 900 SCU Control board at all times. Verify SCU is powered from either 120VAC Utility supply, 120VAC Generator supply, or 24Vdc aux supply (if fitted).</p>
	<p>SCU USB Jumper (J24 on SCU PCB) is in the incorrect position</p>	<p>Verify SCU USB Jumper (J24 on SCU PCB) is in the "GHC" position.</p>

**NOTE**

There are no user serviceable components located on the TSC 900 printed circuit board. If the TSC 900 controller (i.e. SCU or GHC) are deemed to be defective, they must be returned to the Thomson Power Systems Factory for repair or replacement. Please refer to Product Return Policy section of this manual further information on product return procedures required.

**16. REPLACEMENT PARTS**

Replacement parts are available for the transfer switch as follows:

**NOTE**

When ordering replacement parts please provide the following information:

- Transfer Switch Model code (e.g. TS 873AA0200AS)
- Transfer Switch Serial Number (e.g. W-022345)

The above information can be found on the transfer switch equipment rating plate located on the outside of the ATS door



Component Description	Thomson Power Systems Part Number	Comments
TSC 900 SCU Controller Service Replacement	TSC900SCUSR	Must program set points via software prior to use. Refer to TSC 900 Instruction Manual.
TSC 900 GHC Display Service Replacement	TSC900GHCSR	Contact Thomson Power Systems Service Dept. for installation procedures.
Limit Switch 1 n/o, 1 n/c (all ATS Models)	004929	Must install and adjust for proper operation before use. Contact Thomson Power Systems Service Dept. for installation/adjustment procedures
Transfer Switch Motor (100A-250A S Style Mechanism) 120V 20 watt 1 PH	007701	Motor is supplied with gear box assembly. Contact Thomson Power Systems Service Department for installation procedures
Transfer Switch Motor (400A-800A S Style Mechanism) 120V 30 watt 1 PH	007961	Motor is supplied with gear box assembly. Contact Thomson Power Systems Service Department for installation procedures
Transfer Switch Motor (1000A-1200A T-Style Mechanism) 120V 1/10 hp 1 PH	001075	Motor is supplied with gear box assembly. Contact Thomson Power Systems Service Department for installation procedures
120VAC Load Relay (LR), 14 pin Square	001276	Must ensure coil voltage is correct
120VAC 10A Auxiliary Plug-in Relay, 11 pin Square (UX/GX)	001278	Must ensure coil voltage is correct

Component Description	Thomson Power Systems Part Number	Comments
120VAC Auxiliary Plug-in Timer	001515	Must ensure coil voltage is correct
100VA Control Transformer	002159	

For other parts not listed, please contact Thomson Power Systems.

## 17. PRODUCT RETURN POLICY

Thomson Power Systems uses a Return Material Authorization (RMA) process. Please complete the [Return Authorization Request Form](#) (available on our web page) for return of goods, warranty replacement/repair of defective parts, or credit consideration and fax to the appropriate department.

**Returns only:** Email [sales@thomsonps.com](mailto:sales@thomsonps.com)

**Warranty replacement/Warranty Repair:** Email [support@thomsonps.com](mailto:support@thomsonps.com)

Upon receipt of your request, Thomson Power Systems will confirm with a copy of our Order Acknowledgement via fax advising the RMA number which should be used to tag the defective controller prior to shipment.



## 18. NOTES





## 19. PERFORMANCE TEST FORM

This form should be retained by those in charge of the building electrical installation in order to be available to the authority having jurisdiction.

Date	Personnel	Tests performed	Comments
		Interconnection evaluation	
		Grounding point evaluation	
		Fault current test:	
		Ground fault settings - _____	
		Simulated current - _____	
		Results - _____	





# **APPENDIX “A”**

THOMSON POWER SYSTEMS®



**NOTE:** The following commissioning procedures are provided for general information only pertaining to typical site installations and applications. Contact Thomson Power Systems for further information as may be required.

## **A) Pre-Energization Checks**

1. Verify the generator and utility supply voltages match the model of the ATS ordered. If a different voltage is required, refer to procedure in Appendix B for voltage change programming procedure.
2. Confirm power cable size is correct for the lugs supplied in the transfer switch (line, load, and neutral) and are properly torqued.
3. Confirm transfer switch has been adequately grounded per NEC/CEC requirements.
4. Confirm power cables have been Insulation Resistance Tested to ensure no cross phase connections or conduction to ground.
5. Check to ensure there is no mechanical damage.
6. Check to ensure no packaging materials or tools are left inside the transfer switch.
7. Verify control wiring connected to terminal blocks are properly installed (i.e. no frayed ends, screws are tight, no damage, etc.).
8. Ensure ATS Power Chassis & Voltage Sensing Isolation Plugs (PL12 & PL15) are inserted and all TSC 900 Controller plugs are inserted prior to operation.
9. Visually verify the transfer switch mechanism is closed in the utility position as indicated on the mechanism cover.
10. Verify correct control wire interconnects have been installed to the generator set auto start/stop controls.

**NOTE:** The ATS Engine Start contact closes to start the engine and opens to stop the engine.

11. Ensure the inside of the transfer switch is clean from all dust, and other foreign materials.
12. Close ATS enclosure door and tighten all door screws.
13. Visually verify on the transfer switch enclosure that there are no gaps, holes, or potential for water ingress.

## APPENDIX “A”

THOMSON POWER SYSTEMS®



### TYPICAL TS 870 ATS COMMISSIONING PROCEDURES (S-Style 100A-800A)



### B) Equipment Energization

#### DANGER

#### HAZARD OF ELECTRICAL SHOCK, EXPLOSION, OR ARC FLASH

**This equipment must be serviced only by qualified electrical personnel utilizing safe work practices and appropriate Personal Protective Equipment (PPE). Many components of this equipment operate at line voltage. DO NOT TOUCH. Use only electrically isolated tools. Failure to do so may cause personal injury or death**

6. Confirm Utility, Generator and loads can be energized in a safe manner.
7. Energize utility supply and wait approximately 2 minutes for the TSC 900 Display to successfully perform an initial boot-up process. A Thomson Power Systems Logo will be displayed during the booting process.



**NOTE:** under normal operation, TSC 900 Display will not require a re-booting process due to use of a control power reservoir circuit which maintains DC control power under normal operating sequences

8. Once the TSC 900 has successfully completed the boot-up process, confirm utility voltage on the TSC 900 DISPLAY Home page is displaying the correct voltage to match the rating of the ATS, and the ATS Mechanism is in the Utility position.
9. To allow any changes to the TSC 900 controller settings, A Security Login level of Admin or Power must be entered into the TSC 900 Controller (Refer to TSC 900 O&M Manual or TS 870 Quick Start Guide) for further Security programming details.

**NOTE:** Initial Factory Default Password is: **pass** For security purposes, it is strongly recommended to change the group passwords from the factory defaults.

10. Set the TSC 900 Internal time clock – On the TSC 900 DISPLAY, navigate to System screen and press Date/Time Setup button as shown below. Select calendar date/year and enter time in HR:MIN

# APPENDIX "A"

THOMSON POWER SYSTEMS®

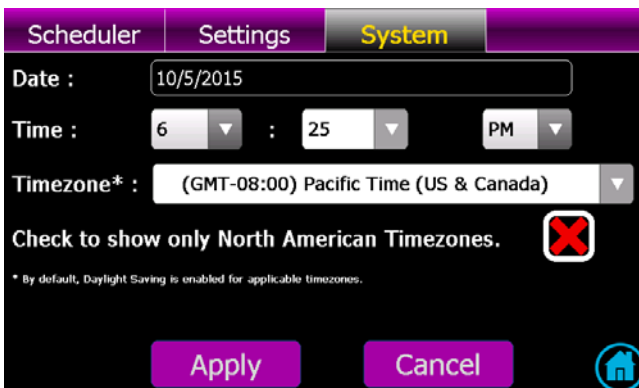
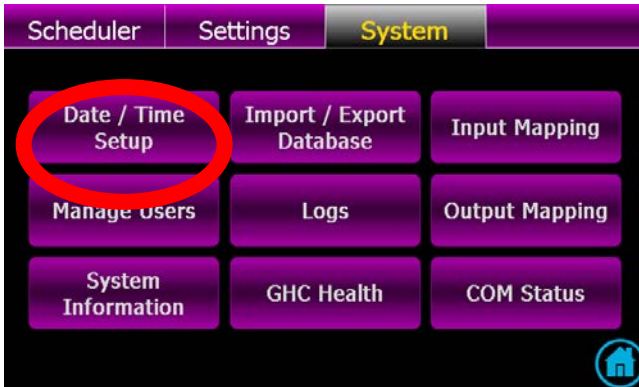

11. Verify the status of the following indicator lights on the TSC 900 Display Home page:
  - Utility Source Green light is On
  - Load on Utility Green light is On
12. Run the generator manually and confirm generator voltage on the TSC 900 DISPLAY Home page is displaying the correct voltage to match the rating of the ATS.
13. With generator still running, confirm generator phasing matches that of the Utility supply by viewing the Utility and Generator metering pages with phase rotation indication on the TSC 900 DISPLAY. If phase rotation does not match, de-energize ATS and re-confirm supply rotation and power wiring is correct.
14. Verify the TSC 900 DISPLAY Home Page Generator Source Red Light is On
15. Manually stop generator and place the generator controls in the Automatic position.
16. To confirm automatic starting and load transferring of the generator, press the Change Mode control button on the TSC 900 DISPLAY home page and select On Load Test mode. The generator will start

## **APPENDIX “A”**

THOMSON POWER SYSTEMS®



### **TYPICAL TS 870 ATS COMMISSIONING PROCEDURES (S-Style 100A-800A)**

and transfer on load per Automatic Sequence. The following lights on the TSC 900 Display home page should be on: Generator Start, Generator Source available and Load on Generator Red light.

17. To stop the generator and transfer load back to the utility supply, press the Change Mode control button on the TSC 900 DISPLAY home page and select Return to Auto mode. The load will re-transfer back to the utility power as per Automatic Sequence.
18. Perform a utility power outage test by opening the upstream utility feeder breaker to the ATS. The TSC 900 Display Utility Supply available light will turn off; the generator set will start after the three second engine start delay has expired and the generator will start and transfer on load as per Automatic Sequence.
19. Return Utility supply voltage to the ATS by re-closing the upstream utility breaker. The load should re-transfer back to the utility supply as per Automatic Sequence.

# APPENDIX “B”

THOMSON POWER SYSTEMS®



## TS 870 SYSTEM VOLTAGE CHANGE PROCEDURE

The system voltage change procedure is a 2 step process 1) ATS Potential Transformer Tap Change and 2) TSC 900 Software Programming. Details of each step are as follows:

### 1) ATS Potential Transformer Tap Change



#### HAZARD OF ELECTRICAL SHOCK, EXPLOSION, OR ARC FLASH

**This equipment must be serviced only by qualified electrical personnel utilizing safe work practices and appropriate Personal Protective Equipment (PPE).**

**Many components of this equipment operate at line voltage. DO NOT TOUCH. Use only electrically isolated tools.**

**Install and close all covers before applying power to this equipment**

**Do not open covers to equipment until ALL power sources are disconnected**

1. Ensure all power sources are de-energized and are safely Locked-out from service prior to opening the transfer switch enclosure door.
2. Disconnect AC Sensing and ATS Power Chassis Circuit Isolation Plugs PL12 & PL15.
3. Change voltage transformer primary taps settings as follows to match new system voltage on all potential transformers (PTs). (Refer to wiring schematic diagram below).

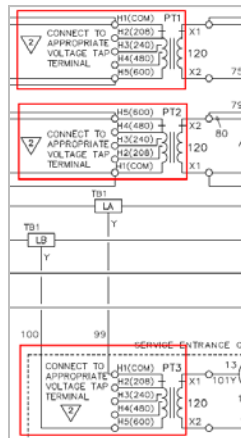

## APPENDIX "B"

THOMSON POWER SYSTEMS®



### TS 870 SYSTEM VOLTAGE CHANGE PROCEDURE

- Carefully remove the potential transformer high voltage side covers by prying up on the edge of the cover with a ¼" Flat Head Blade screwdriver and lifting off.



**NOTE:** You can also use your finger to pry up on the edge of the PT cover.

- Remove the screw on the PT Tap which is the correct voltage selected for the application (i.e. H2-208V, H3-240V, H4-480V or H5-600V)

H6-Not Used    H5-600V    H4-480V    H3-240V    H2-208V    H1 (Never Changes)





## APPENDIX "B"

THOMSON POWER SYSTEMS®



### TS 870 SYSTEM VOLTAGE CHANGE PROCEDURE

**CAUTION:** Brace PT terminal block with your hand when loosening or tightening ANY screws.

6. Remove the screw and red ring terminal connected to the incorrect (existing) PT voltage terminal. Install the screw and red ring terminal to the new selected PT Tap Terminal based on required voltage and tighten while supporting the terminal block. Make sure the ring terminal is not misaligned or the PT cover will not fit back on.

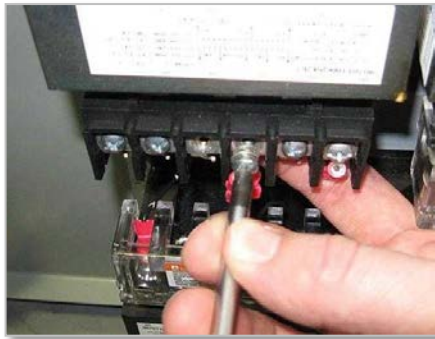

7. Install the extra screw back onto the old PT location and tighten.



#### **CAUTION**

**Confirm that PT screws are correctly tightened, and do not put strain on the PT Tap wires.**

8. Replace the PT cover. PT covers should 'snap' in place, confirm they are installed correctly by gently "twisting" the PT cover. DO NOT use excessive force.
9. Repeat the steps 1 to 5 for all Potential Transformers.

**NOTE:** 2 to 3 PT's will be installed in the Transfer Switch depending on the Model type.

# APPENDIX “B”

THOMSON POWER SYSTEMS®

	<b>TS 870 SYSTEM VOLTAGE CHANGE PROCEDURE</b>
---	---

## 2) TSC 900 Software Programming

To change system voltage on the TSC 900 controller, the transfer switch must be energized to provide control power to the controller to allow software programming. If safe to do so, energize Transfer Switch on either Utility or Generator sources and follow the programming procedure shown below.

**NOTE:** The TSC 900 controller does not contain any system voltage jumpers on the printed circuit board. All voltage changes are done via software programming only.

1. **Security Password Login:** To allow a change in voltage setting, a Security Login with a level of “POWER” or “ADMIN” is required. Navigate to the “HOME” Page and select the Security Lock Icon located on the upper right hand corner per screen shot shown below. A pop-up Security Login Page will appear. Next from the Security Login Page, Select User Name drop down box and choose (POWER or ADMIN), then type in password, then select “Apply” button. Refer to TSC 900 O&M Manual or TS 870 Quick Start Guide for further Security programming details.

**NOTE:** Initial Factory Default Password is “*pass*”

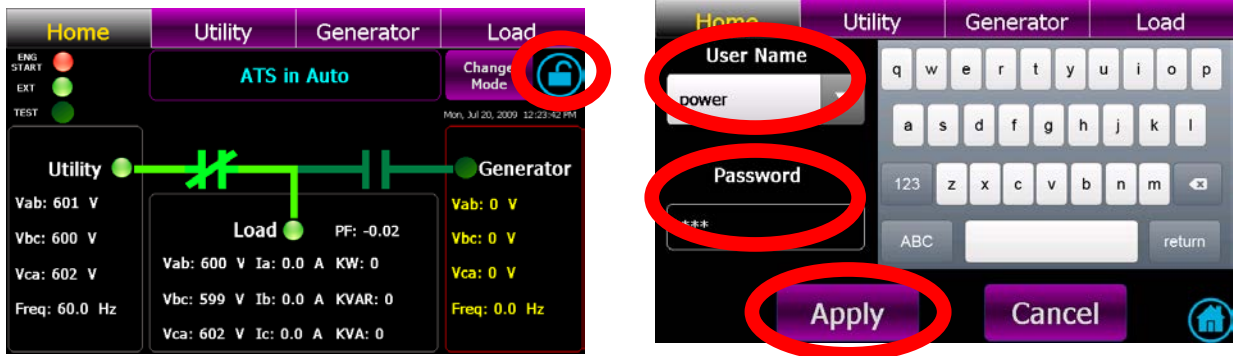



# APPENDIX "B"

THOMSON POWER SYSTEMS®



## TS 870 SYSTEM VOLTAGE CHANGE PROCEDURE

- Once successfully logged in, From the TSC 900 DISPLAY Home Page, Navigate to the Settings Page below and select System Voltage as shown below.

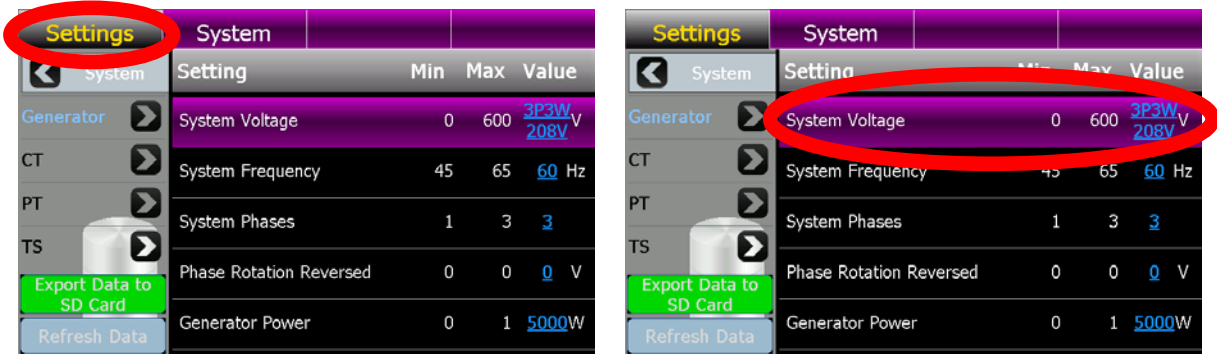

- On the System Voltage Row, select the underlined System Voltage value and from the drop down list which appears, select the desired voltage for the application as shown below. To confirm the change, press the Apply button.

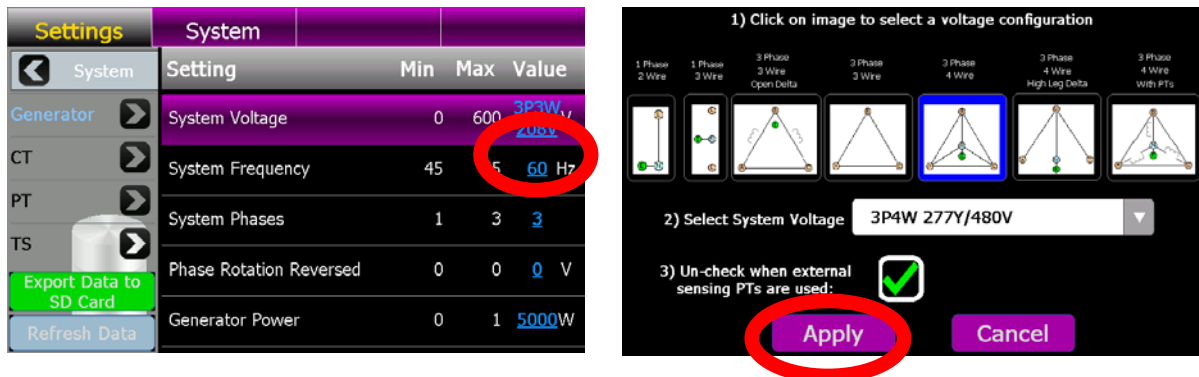





## SEISMIC CERTIFICATE



### Seismic Certification

#### Thomson Technology – Automatic Transfer Switches TS 840, 870, 880 Approved for use in Seismic Applications

Thomson Technology has seismically certified its line of **Automatic Transfer Switches** including all models of **TS 840, 870, 880**. The certification was done by shake-table testing according to the nationally recognized standard, AC156. The standard covers seismic design requirements for non-structural components according to IBC 2006 and ASCE7-05.

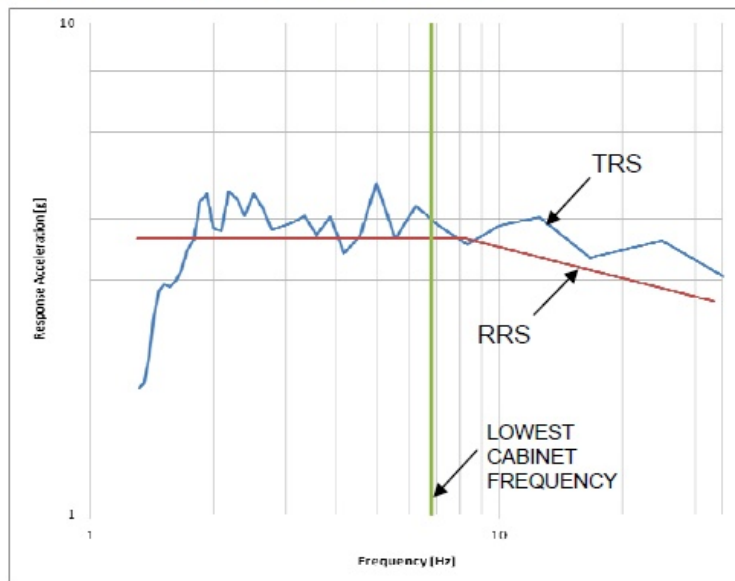

**Dr. Carlos E. Ventura, PE**  
Director, TVP Engineering Ltd.  
Certifying Company



**Norm Schmidt**  
Vice President, Engineering and Administration  
Thomson Technology

*Shake-table tests were performed at Alpha Seismic and Environmental Test Laboratory and the Earthquake Engineering Research Facility, University of British Columbia. The figure shows a representative Test Response Spectrum (TRS) plotted with 5% damping against the AC156 Required Response Spectrum (RRS) with a  $S_s$  value of 342%. For more details, please refer to the certification notes.*





**Thomson Power Systems**

9087A - 198th Street  
Langley, BC, Canada V1M 3B1

Customer Support: 604-888-0110  
Toll Free: 1-888-888-0110  
Sales Email: [sales@thomsonps.com](mailto:sales@thomsonps.com)  
Service Email: [support@thomsonps.com](mailto:support@thomsonps.com)

For Preventative Maintenance or Extended Warranty information contact our Service Department at 604-888-0110 or email [support@thomsonps.com](mailto:support@thomsonps.com)

PM062 REV11 16/04/19

Thomson Power Systems and Regal are trademarks of Regal Beloit Corporation or one of its affiliated companies.

©2018 Regal Beloit Corporation, All Rights Reserved.

