



QUICK START GUIDE

TS 930

800A – 2000A



HAZARD OF ELECTRICAL SHOCK, EXPLOSION, OR ARC FLASH

- Read and understand this quick start guide before installing and operating the transfer switch
- The installer is responsible for compliance with national electrical code requirements with respect to installation of this equipment.
- Many components of this equipment operate at line voltage. DO NOT TOUCH. Use only electrically isolated tools.
- Install and close ATS door before applying power to this equipment
- Do not open door to equipment until ALL power sources are disconnected
- This equipment must be installed and serviced only by qualified electrical personnel utilizing safe work practices and appropriate Personal Protective Equipment (PPE).

Failure to do so may cause personal injury or death

	PAGE
A. Introduction.....	2
B. Check Equipment Delivery	2
C. Check Line Voltage/Amperage	2
D. Installation Requirements	2
E. ATS Interior Component Layout (Typical).....	3
F. ATS Controller Description	4
G. Power Contactor Description.....	6
H. Electrical Ratings/Enclosure Dimensions/Cable Terminals.....	7
I. Customer Control Wiring Connections.....	8
J. AC Voltage Change Procedures.....	9
K. Equipment Energization Procedure	14
L. ATS Manual Operation	16
M. TS 930-DS Schematic Diagrams.....	18
N. TS 930-CA Schematic Diagrams.....	20

A. Introduction

Thank you for purchasing a Thomson Power Systems product. This quick start guide applies to TS 930 Transfer Switches rated 800Amp through 2000Amp. For other product types please contact Thomson Power Systems.

This quick start guide contains all the information you need to install and set up your new Thomson Power Systems TS 930 Transfer Switch.

To conserve our natural resources, your transfer switch does not include a printed owner's manual. An owner's manual containing complete information about operating all of your new transfer switch features is available at our Web site. Go to www.thomsonps.com and download TS 930 Owner's Manual.

NOTE: All information contained in this quick start guide is for reference only and is subject to change without notice.

B. Check Equipment Delivery

Upon delivery of the transfer switch, remove the product packaging and verify the product has not been damaged.

 **WARNING Damaged Transfer Switch equipment:** Do not install or operate the transfer switch if it appears damaged. **Failure to follow these instructions can result in death, serious injury, or equipment damage.**

Check that the model number printed on the inside door of the transfer switch is the same as on the delivery note corresponding to the purchase order.

C. Check Line Voltage/Amperage

The Transfer Switch is designed for a maximum voltage of 480V, Three Phase 3 wire with neutral or Three Phase 4 wire with neutral. Verify the line voltage and amperage of the transfer switch matches the site requirements.

NOTE: The transfer switch can be configured for operation on 220V sources by way of configuration jumper. Refer to **Section I** of this guide for further information.

 **WARNING** Do not install the transfer switch if either voltage or amperage does not match. **Failure to follow these instructions can result in death, serious injury, or equipment damage.**

D. Installation Requirements

Before installing the transfer switch, review the following requirements:

- **ATS Standards:** The TS 930 ATS series is manufactured in accordance with IEC 947-6 ATS performance standards. The TS 930 is not intended for installation in areas requiring UL or CSA certifications.
- **Installation Location:** The standard TS 930 transfer switch is designed for indoor wall mounting. For applications requiring outdoor wall mounting, a NEMA 3R door **kit is optionally** available. The transfer switch must be installed in an environment where the temperature range is within +5° to +122° Fahrenheit (-15° to +50° Celsius) and humidity range not exceeding 5%-95% non-condensing.
- **Power Cabling:** All power cabling entering/exiting the enclosure must be installed in suitably sized conduits. Ampacity, type and voltage rating of current carrying conductors must also comply with local jurisdictions having authority.
- **Control Wiring:** All control wiring for engine start and DC Control Power must be installed in separate conduits from all power cabling and must utilize suitably sized conduits per local jurisdictions having authority. All control wiring shall be sized for minimum #14 AWG.
- **12/24VDC Control Power:** The TS 930 ATS is designed to accept 12 or 24Vdc, 3.0Aac (MAX) control power from a continuously supplied DC power source such as Engine starting batteries. If Engine starting batteries are utilized, a battery charger is required to maintain battery voltage at a sufficient level when the generator set is not in operation.
- **Generator Set Automatic Start Operation:** The TS 930 transfer switch operates in conjunction with any generator set with remote automatic starting capabilities utilizing a 2 wire, remote start control contact input. A dry contact is provided for remote generator starting control (contact closes to start generator and opens to stop generator).
- **Upstream Overcurrent Protection:** TS 930 transfer switch models do not contain any integral over current protection and require upstream over current protection devices for both Utility and Generator sources. The standard TS 930 is suitable for control of motors, electric discharge lamps, tungsten filament lamps, and electric heating equipment where the sum of motor full-load ampere ratings and the ampere ratings of other loads do not exceed the ampere rating of the switch and the tungsten load does not exceed 30 percent of the switch rating. The Standard TS 930 is rated for 100% continuous loading subject to load content described above and can withstand a maximum short circuit fault current as noted in **Section H** of this document.
- **Withstand Current Ratings:** Refer to electrical ratings shown in **Section H** below for withstand current ratings.

 **WARNING** Do not install the transfer switch on systems with higher available short circuit current levels than listed in the Table in **Section H**. **Failure to follow these instructions can result in death, serious injury, or equipment damage.**

E. ATS Interior Component Layout (Typical)

2000A, 3 Pole Model Shown

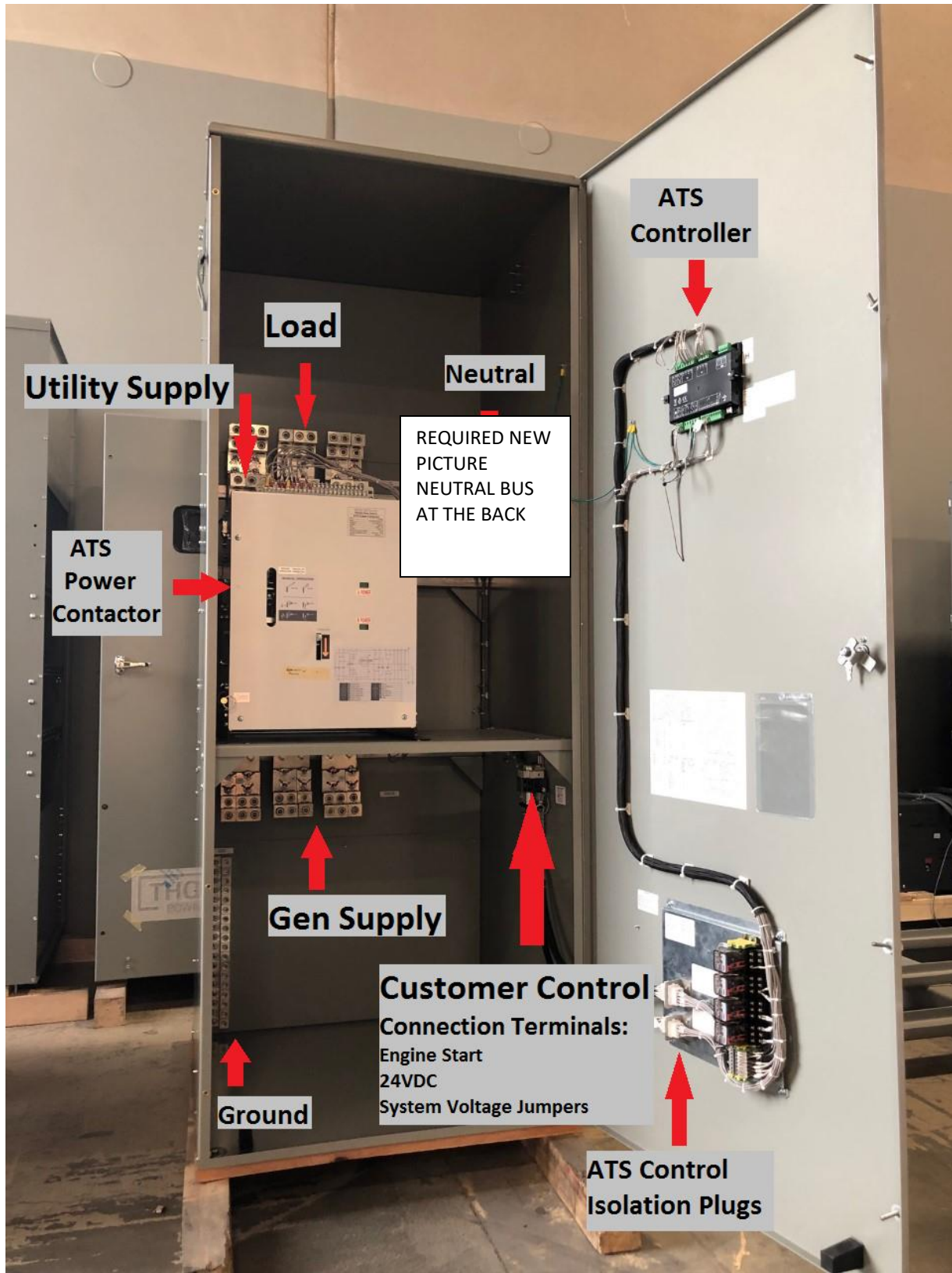

F. ATS Controller Description

The TS 930 Automatic Transfer Switch is available with two different ATS controllers (DeepSea Electronics™ or CompAP™) which must be specified at time of ATS order. Each ATS controller provides 3 phase utility voltage sensing and upon loss of utility power, will automatically transfer to the generator supply as soon as it reaches normal voltage and speed. When the utility supply returns, the ATS will automatically re-transfer back to the utility supply after time delay.

Each controller provides a door mounted faceplate with LCD display and operator pushbuttons to select operating modes or to view system parameters. For detailed information on the ATS controller supplied, refer to the ATS controllers' original manufacturer instruction manuals supplied with the ATS or download from Thomson Power Systems website.

a) DeepSea Electronics™, Model DSE334

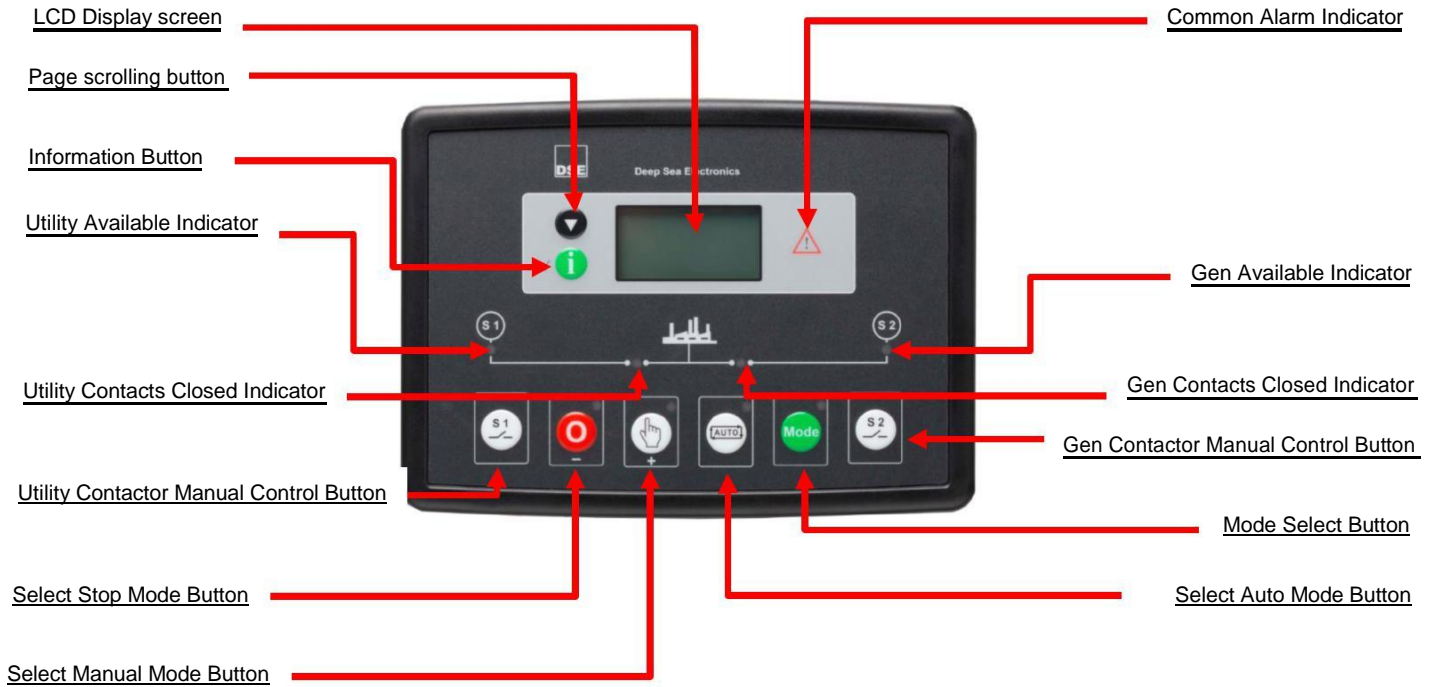

b) ComAP™, Model InteliATS^{NT}-PWR

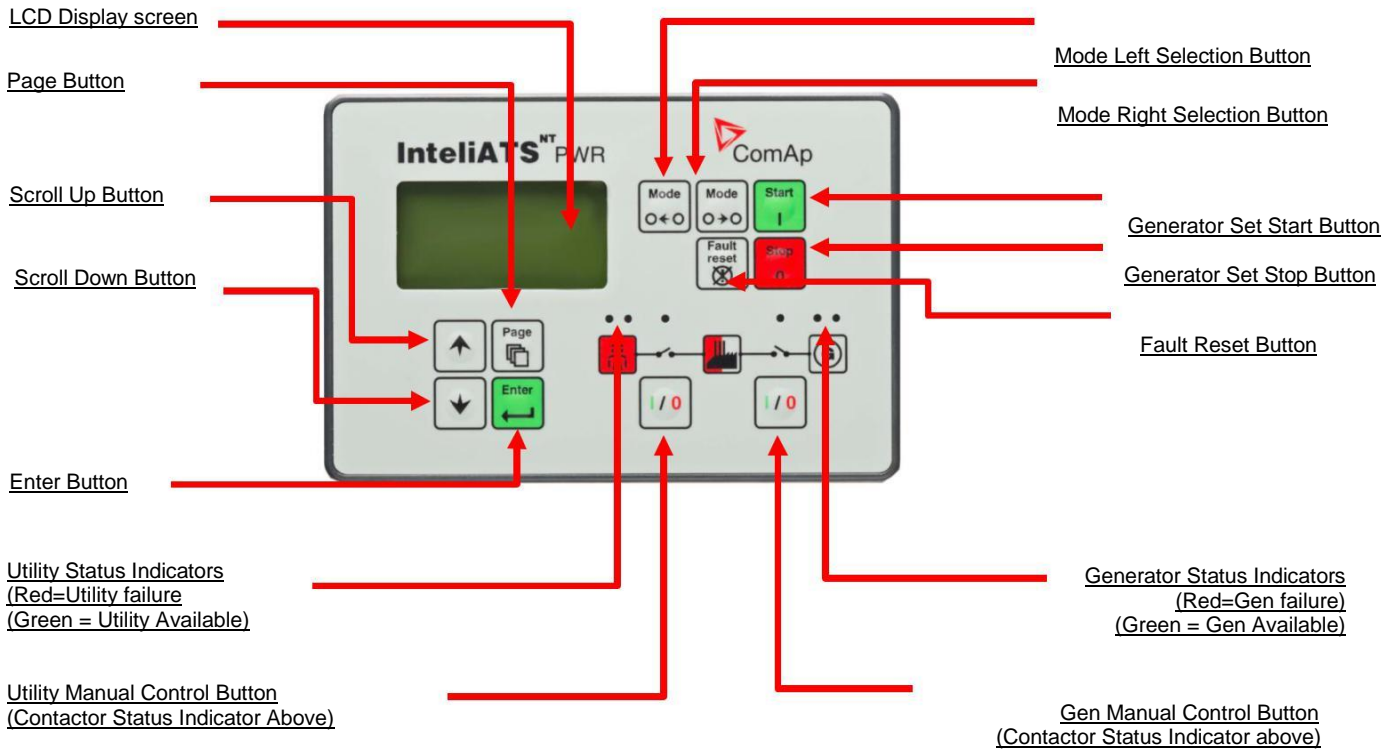

G. Power Contactor Description

2000A, 3 Pole Model Shown

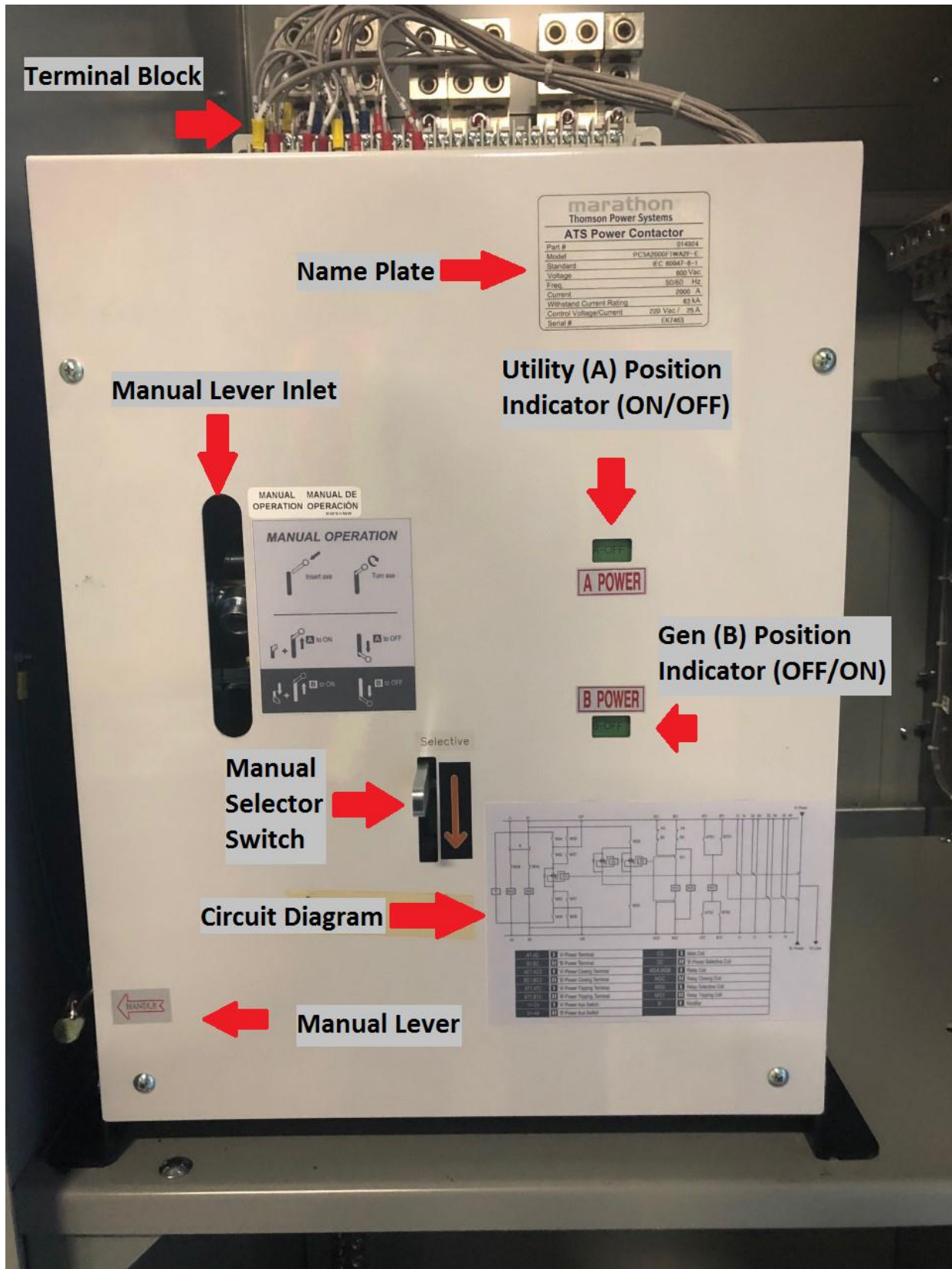

H. Electrical Ratings/Enclosure Dimensions/Cable Terminals

The transfer switch is provided with power cable lugs for line, load and neutral block as per sizes indicated in the Table below. All Power cables are to be installed and torqued on the lugs per values indicated on the inside of the ATS door.

 **WARNING** Failure to properly install and adequately tighten power cable connections can result in equipment malfunction and/or damage

MODEL	AMPERAGE	MAX VOLTAGE	POLES	WITHSTAND CURRENT RATING (Icm @ 480VAC)	DIMENSIONS ₁			SHIPPING WEIGHT lbs (kg)	TERMINAL RATING ₂	
					HEIGHT INCHES	WIDTH INCHES	DEPTH INCHES		QTY (PER PHASE)	RANGE
TS933A0800A	800A	480V	3	25kA	74" (1880)	30" (762)	26" (660)	570 lbs (259)	4	#4 - 600 mcm
TS933A1000A	1000A	480V	3	25kA	74" (1880)	30" (762)	26" (660)	570 lbs (259)	4	#4 - 600 mcm
TS933A1250A	1250A	480V	3	30kA	74" (1880)	30" (762)	26" (660)	585 lbs (265)	4	#4 - 600 mcm
TS933A1600A	1600A	480V	3	35kA	74" (1880)	30" (762)	26" (660)	600 lbs (272)	4	#4 - 600 mcm
TS933A2000A	2000A	480V	3	40kA	84" (2134)	33" (838)	33" (838)	850 lbs (386)	6	#4 - 600 mcm

NOTE Before insulation resistance testing is conducted, the Transfer Switch Controller must be isolated from the power wiring by unplugging all green colored ATS wiring plugs). Refer to Photos show below. Failure to isolate the ATS controller for insulation resistance testing can result in equipment malfunction and/or damage.



DeepSea™ Controller



ComAP™ Controller

Following power cable installation, and isolating the ATS controller, all power cables shall be appropriately insulation resistance tested to ensure no cross phase connections or conduction to ground.

Once insulation resistance testing is complete, re-insert all the ATS controller isolation plugs

I. Customer Control Wiring Connections

All control wiring connections are made to the terminal block located on the right-hand side wall of the enclosure per the following photo and schematic diagram.

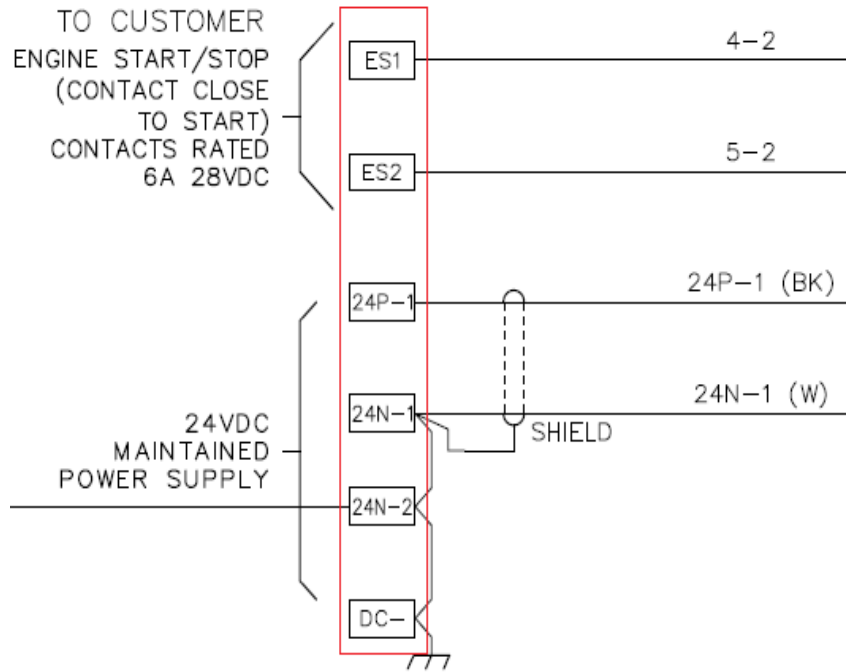
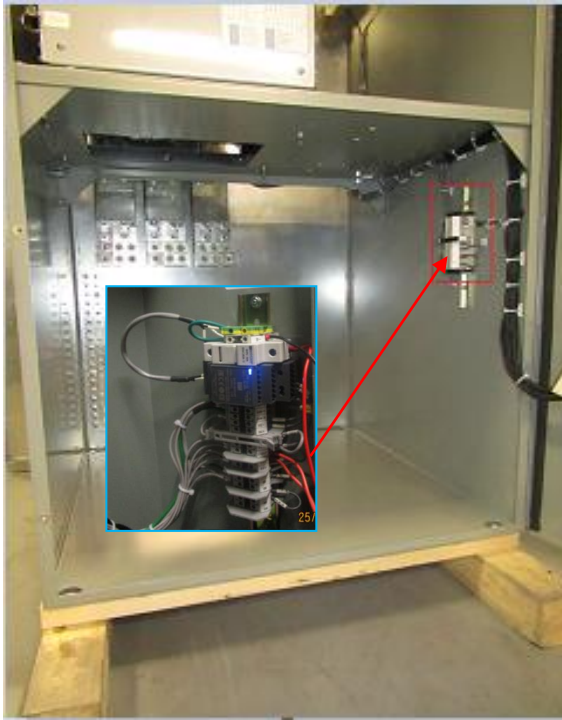

J. AC Voltage Change Procedures

The following procedures must be followed to change the ATS from the factory default AC voltage setting of 480VAC 3 Phase 4 wire to 120/208V or 127/240V 3 phase 4 wire.

1. Terminal block Jumper Changes

De-energize all AC Power, open the ATS door and locate the terminal blocks on the right-side sheet.

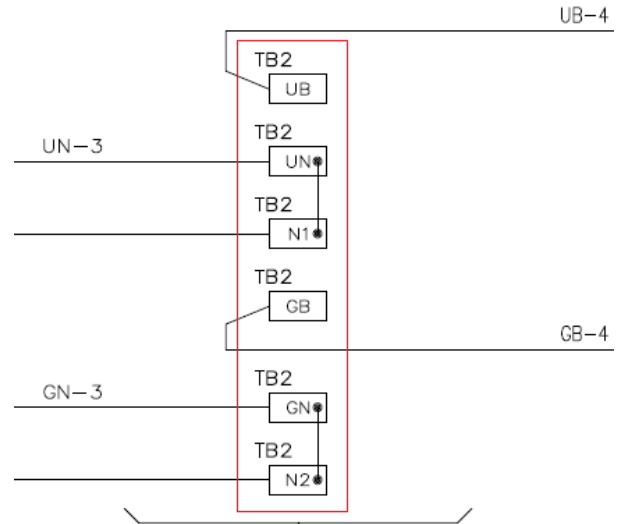

JUMPERS FOR VOLTAGE CONFIGURATION	
1	120/240V CONFIGURATION, JUMPER UB TO N1, GB TO N2
2	277/480V CONFIGURATION, JUMPER UN TO N1, GN TO N2



180V configuration, connect N1 to UN, and N2 to GN.

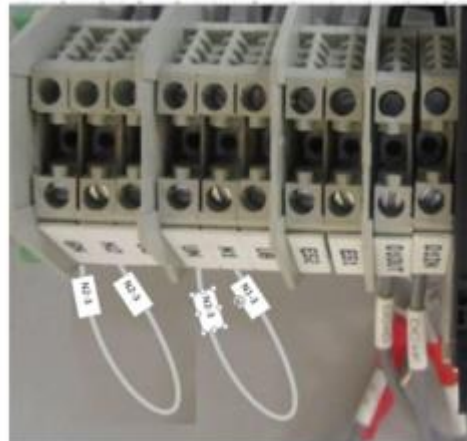
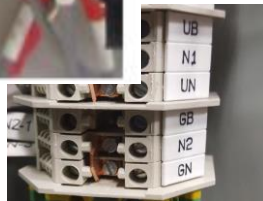

For 120/240V configuration, connect UB to N1, and GB to N2.

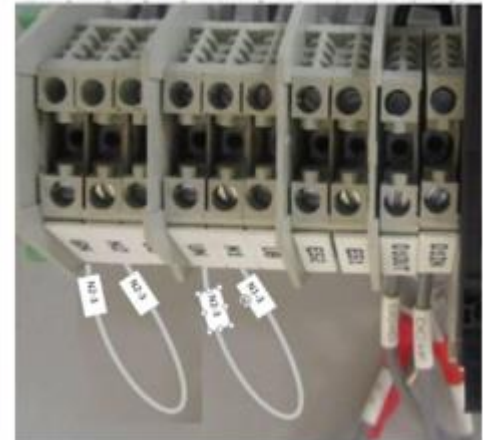
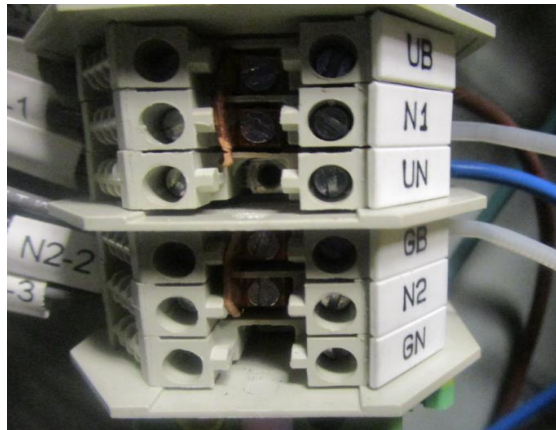

NOTE: Move the jumper back to N1-UN and N2-GN for 277/480V configuration, fail to do so will cause the damage to the contactor coil.

2. Deepsea™ ATS Controller System Voltage Programming

2.1 Install the latest DEEPSEA configuration suit file in the laptop.

Download from <https://www.deepseapl.com/ats/automatic-transfer-switch-control-modules/dse334/software>

2.2 Connect the DEEPSEA controller to a laptop via a USB cable.



2.3 Double click the 240V configuration file provided by Thomson Power Systems.



2.4 Choose USB Connection and the device will be automatically detected.



2.5. Press the Write To Device icon to transfer the configuration file to controller.



A popup window will indicate the progress of downloading and click on OK once it reaches 100%

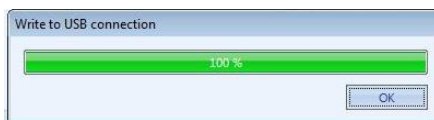

Close the DSE configuration suit and disconnect the USB cable.
The ATS has been successfully configured to 120/240V.

3.ComAP™ ATS Controller System Voltage Programming

3.1 Press the Page button under the display to enter into the setting menu.

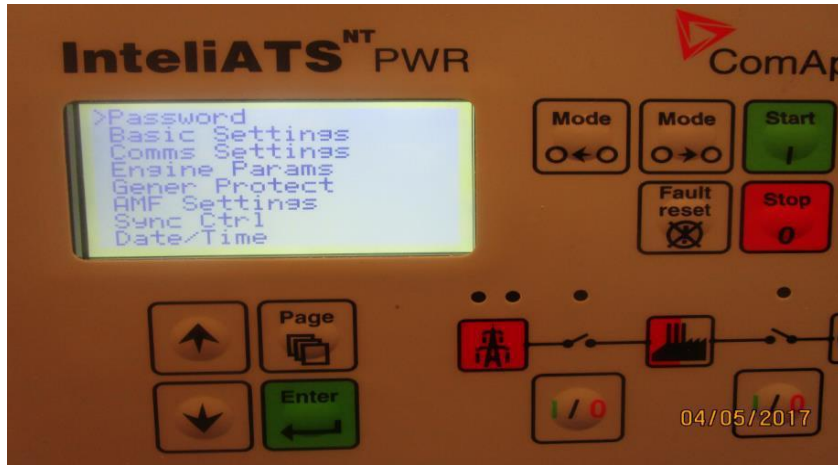

3.2 Select the Basic Settings by pressing the Down button and hit the Enter.

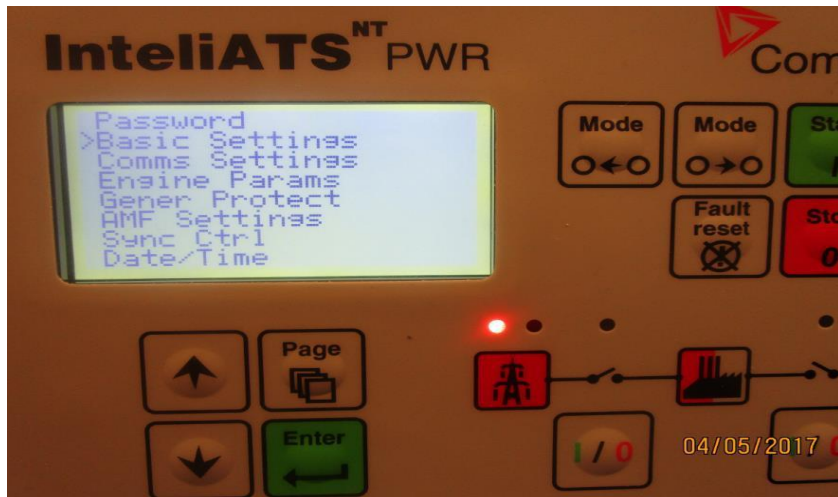

3.3. Press the Down button to navigate to NomVolts PH-PH.

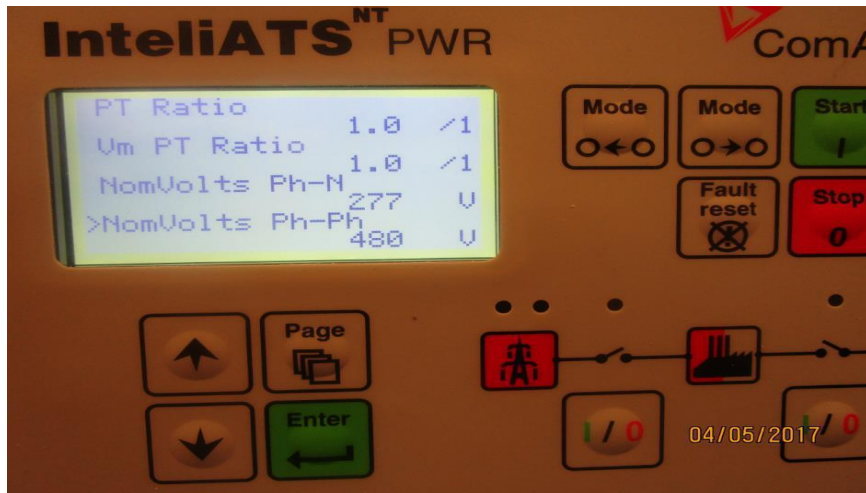

3.4 Press Enter and use Down button to adjust the value to 240V, then press Enter to save the value. NomVolts PH-N will be automatically changed to 139V.

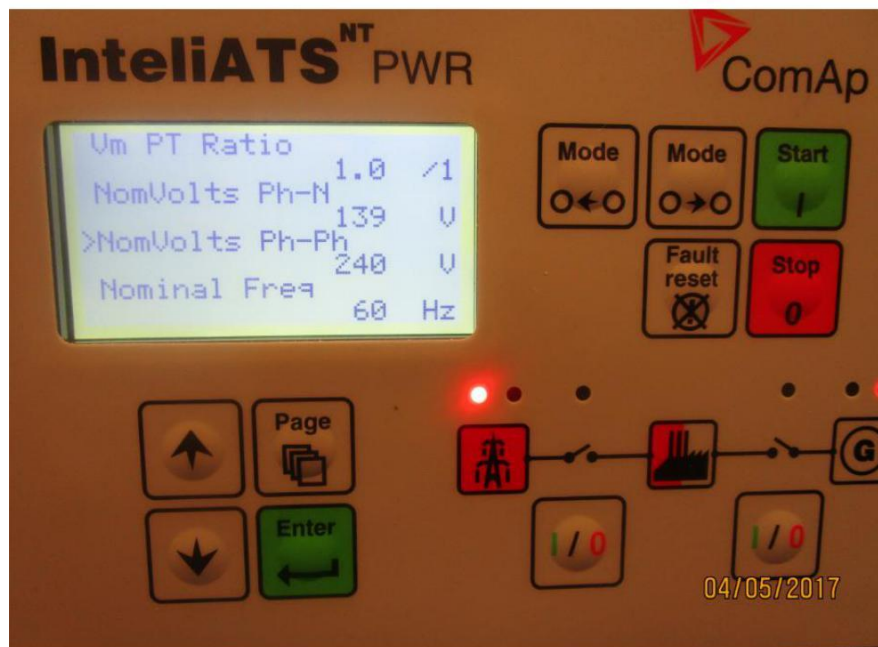
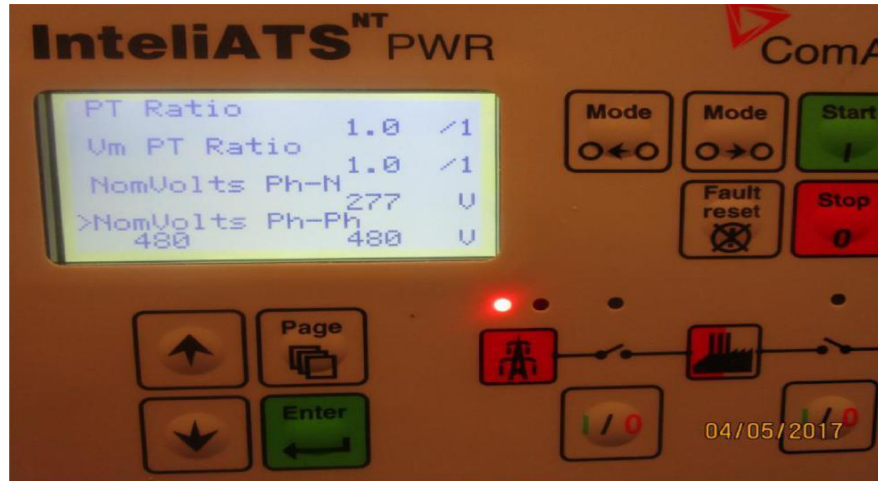

The ATS has been successfully configured to 120/240V.

Note. COMAP does not provide the selection of specific voltage configuration like high-leg delta 120/240V. The over and under voltage protection is evaluated according to the PH-PH voltage if user chooses 3Ph4wire as connection type.

HINT:

Over- and undervoltage protection is evaluated according to [Basic Settings: ConnectionType](#) setting. 3Ph4Wire and 3Ph3Wire connections are evaluated according to Ph-Ph nominal voltage (NomVolts Ph-Ph) and Split Phase and Mono Phase connections are evaluated according to Ph-N nominal voltage (NomVolts Ph-N).

K. Equipment Energization Procedure

1. Pre-Energization Checks

1. Verify the generator and utility supply voltages match what the ATS is configured for (i.e. 120/240V single phase, 127/220V 3 phase, 277/480VAC). If required- reconfigure Voltage jumpers as required (refer to **Section I**).
NOTE: The ATS is supplied with Factory Default Voltage Setting for **480VAC**
2. Confirm power cable size is correct for the lugs supplied in the transfer switch (line, load, and neutral) and are properly torqued.
3. Confirm transfer switch has been adequately grounded per local requirements.
4. Confirm power cables have been Insulation resistance tested to ensure no cross phase connections or conduction to ground.
5. Check for mechanical damage.
6. Check no packaging materials or tools are left inside the transfer switch.
7. Verify 24Vdc, 3.0-amp (Max) DC control power is available and is properly connected (i.e. no frayed ends, screws are tight, no damage, etc.).
8. Verify correct control wire interconnects have been installed to the generator set auto start/stop controls. **NOTE:** The ATS Engine Start contact CLOSES to start the engine and OPENS to stop the engine.
9. Ensure all ATS Controller green terminal blocks are plugged in correctly prior to operation.
10. Verify ATS Voltage Sensing and Control Isolation Plugs (i.e. PL-12 & PL-15) are connected prior to operation.
11. Visually verify the transfer switch power contactor is closed in the utility (A) position. To manually operate refer to **Section K**
12. Ensure the inside of the transfer switch is clean from all dust, and other foreign materials.
13. Close the enclosure door and tighten all door screws.
14. Visually verify on the transfer switch enclosure that there are no gaps, holes, or potential for water ingress.

2. Equipment Energization



DANGER

HAZARD OF ELECTRICAL SHOCK, EXPLOSION, OR ARC FLASH

- This equipment must be serviced only by qualified electrical personnel utilizing safe work practices and appropriate Personal Protective Equipment (PPE).
- Many components of this equipment operate at line voltage. DO NOT TOUCH. Use only electrically isolated tools.

Failure to do so may cause personal injury or death

1. Confirm Utility source and loads can be energized in a safe manner.
2. Energize utility supply and confirm voltage is correct as configured and phase rotation at the utility and load is correct.
3. Energize the 24Vdc nominal control power and ensure the ATS controller powers up.
4. Verify the status of the following indicator lights on the ATS Controller:
 - Utility Source Available indicator light is illuminated
 - Load on Utility indicator light is illuminated
5. Confirm Generator source can be energized in a safe manner.
6. Open local main generator breaker and start the generator manually from the local control panel and confirm the generator set operates correctly and the generator supply voltage matches the ATS voltage rating.
7. Stop the generator and close its main output circuit breaker
8. Re-start the generator manually and using appropriate personal protective equipment (PPE) and insulated tools/meters, open the transfer switch door while energized and verify at the transfer switch mechanism, the generator supply voltage, phasing and phase rotation is correct (i.e. matches the Utility supply). Once verified, re-close ATS enclosure door.

NOTE

On 3 Phase Systems, the ComAP ATS controller has Phase Rotation miss-match protection. For the ATS to successfully transfer between sources, both the Utility and Generator Source Phase rotation must be matched. Phase rotation on both sources can be either positive rotation (i.e. A-B-C) or negative rotation (C-B-A)

9. Verify the Generator Source Available indicator light is illuminated on the ATS Controller.
10. Manually stop generator and place the local generator control panel to the "AUTOMATIC" position.



11. To confirm automatic starting and load transferring of the generator, perform the following steps:
 - a) To test, change the operating mode of the ATS Controller to "TEST" Mode. The generator should start and transfer on load per Automatic Sequence provided an on-load test is called for.
 - b) Verify the following ATS Controller indicator lights are activated:
 - Generator Source Available indicator light is illuminated
 - Load on generator indicator light is illuminated
12. To stop the generator and transfer load back to the utility supply, return the ATS Controller back to the AUTO mode. The load will re-transfer back to the utility power as per Automatic Sequence.
13. Perform a utility power outage test by opening the upstream utility feeder breaker. The ATS controller will signal an abnormal utility voltage condition and the generator set will start after the engine start delay has expired. Once started, the generator set should start and transfer on load as per Automatic Sequence.
14. Return the transfer switch to utility power by re-closing the upstream utility breaker. The load should re-transfer back to the utility supply as per Automatic Sequence.



L. Manual Operation Procedure

The transfer switch maybe operated manually for maintenance or emergency operation conditions provided both Utility and Generator supplies are de-energized prior to manual operation.



HAZARD OF ELECTRICAL SHOCK, EXPLOSION, OR ARC FLASH

- This equipment must be serviced only by qualified electrical personnel utilizing safe work practices and appropriate Personal Protective Equipment (PPE).
- Many components of this equipment operate at line voltage. DO NOT TOUCH. Use only electrically isolated tools.
- Install and close ATS door before applying power to this equipment
- Do not open door to equipment until ALL power sources are disconnected

Failure to do so may cause personal injury or death

The following photo shows the ATS Power Contactor Mechanism with Manual Operation tools (i.e. Shaft Wrench & Trip/Select Screwdriver) which are supplied loose with the transfer switch

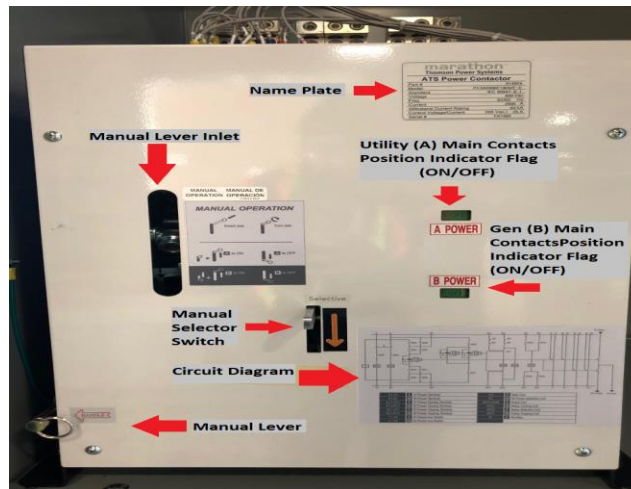

1. Manual Closing to Utility Position (Side A)

- De-energize both Utility and Generator Power sources and lock open.
- With all power de-energized, open ATS enclosure door and locate and remove Manual Operation Handle (Manual Lever)
- Un-plug the ATS control isolation plug (PL-15) to prevent automatic operation (refer to **Section E** for photo showing location of PL-15).
- Trip Open Generator (Side B) Main Contacts by inserting the manual lever into the inlet as shown below and rotating in a clockwise direction. With the Manual selector switch in the down position move the manual lever to the down position. Generator Main Contacts open as shown by the Generator Position indicator flag **OFF**
- Close Utility (Side A) Main Contacts by moving the manual selector switch to the up position and then moving the manual lever to the up position. The Utility Main contacts latch closed as shown by the Utility **ON** indicator.



- f) Once ATS is manually operated to the Utility **ON** position, remove the manual lever from the Power contactor and secure them away from any live power sources.
- g) Close ATS door and re-energize Utility power to return power to the load.

2. Manual Closing to Generator Position (Side B)

- a. De-energize both Utility and Generator Power sources and lock open.
- b. With all power de-energized, open ATS enclosure door and locate Manual Operation Handle (Manual lever)
- c. Un-plug the ATS control isolation plug (PL-15) to prevent automatic operation (refer to **Section E** for photo showing location of PL-15).
- d. Trip Open Utility (Side A) Main Contacts by inserting the manual lever as shown above and rotating in a clockwise direction. With the manual sector switch in the up position, move the manual lever to the down position. Utility Main Contacts open as shown by the Utility Position indicator flag **OFF**
- e. Close Generator (Side B) Main Contacts by holding the manual selector switch in the down position and moving the manual lever to the up position. Gen Main contacts latch closed as shown by the Generator Position indicator flag **ON**.



- f) Once ATS is manually operated to the Generator **ON** position, remove the Shaft Wrench & Screwdriver from the Power contactor and secure them away from any live power sources.
- g) Close ATS door and re-energize Generator power to return power to the load.

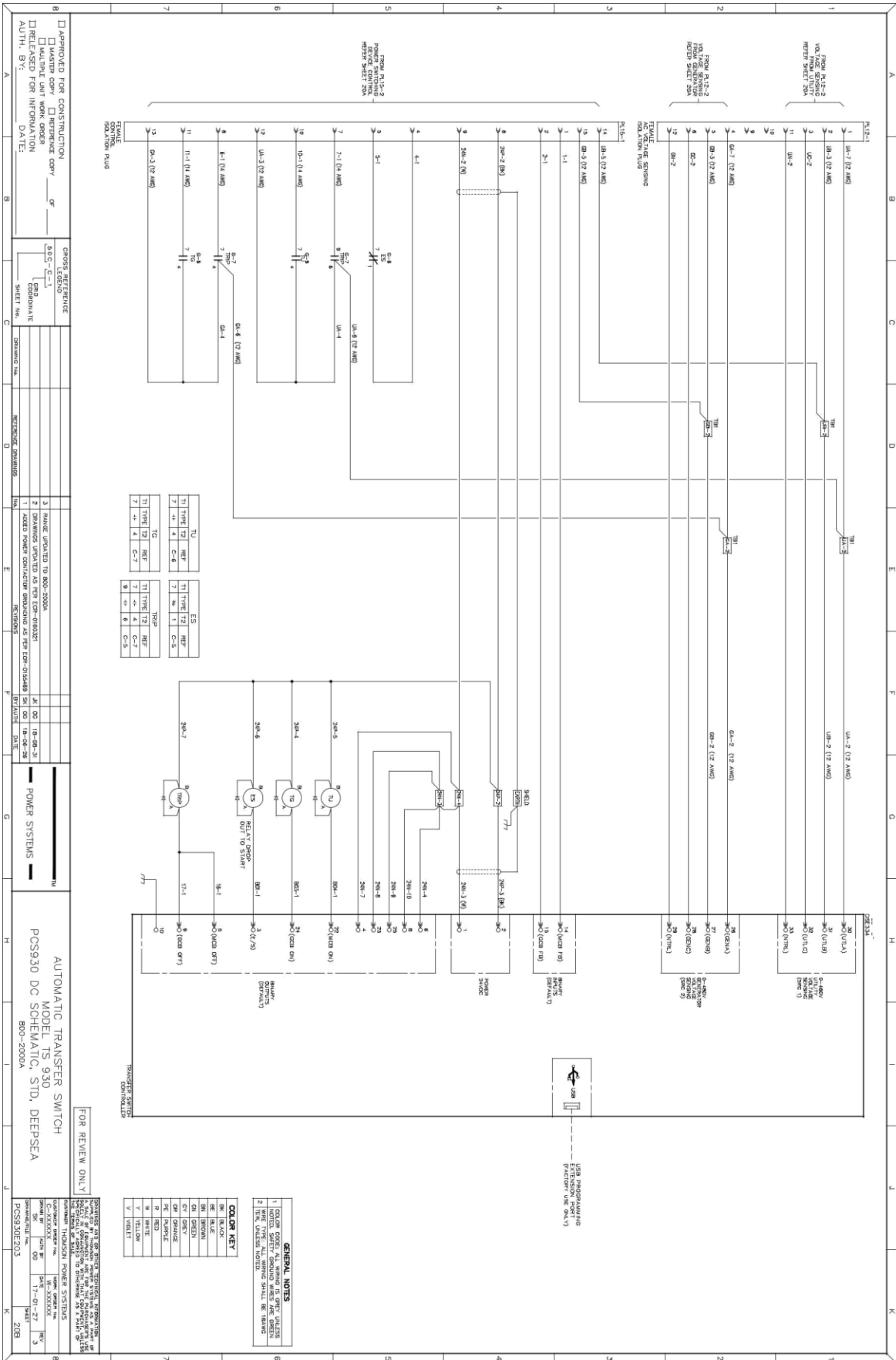

N. TS 930-CA Schematic Diagrams

